

HIGH QUALITY
IMAGING OPTICS
FOR ANY APPLICATION



 **NAVITAR®**

Looking to the Future

Navitar enters into this new decade with excitement! We couldn't help but be inspired by the year 2020. It made us think about perfect vision and the need for imaging solutions that go beyond what is available to our customers today.

Our mission for the year 2020 is to take vision technology further than ever before. We will deliver advanced imaging solutions to customers allowing them to build innovative systems and achieve revolutionary results.

Throughout the coming year, Navitar is introducing new products and technologies with higher resolution, greater fields of view, faster and more repeatable zoom capability, and greater quantum efficiencies.

Look for new 10 GigE camera systems, Optotune lenses for our high magnification imaging systems, new macro lenses, factory automation lenses, camera modules, and more.



Contents

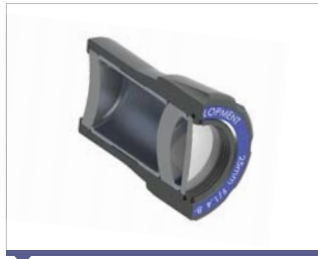

4 Capabilities



8 Resolv4K Lens Series



14 Zoom 6000 / Optotune / 12X Lens Systems



32 Motorized Solutions

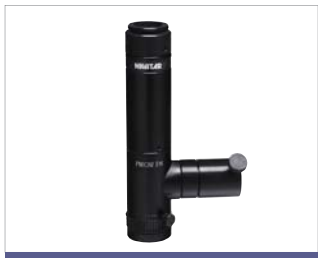

34 Precise Eye Lens System



40 NUV-VIS Zoom System



42 Dual View Lens System



44 MTL System / HR Objectives



47 Autonomous & HDR Lenses



48 Illumination



50 Large Format Lenses



52 FA Lenses



63 Projection Lenses



64 Pixelink Cameras

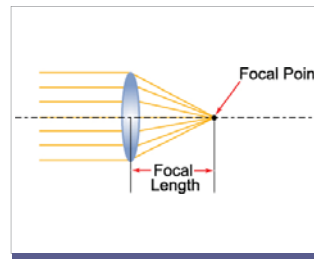

66 Quick Reference

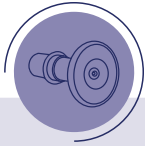

Lenses & Assemblies

Navitar produces high performance, high quality imaging and projection lenses used in a variety of applications. We offer standard off-the-shelf products as well as custom designs and deliver thousands of custom lens assemblies per year.

Whether you are looking for a high magnification zoom lens system with motorization, a wide angle fisheye projection lens, or HDR lenses for autonomous vehicles, Navitar can help with your project.

Our Capabilities:

- Optical, Mechanical and Electro-Optical Design
- Custom Engineering
- Low to High Volume Production
- In-House Manufacturing
- Lens-Sensor Alignment
- OEM Lens Assemblies

Navitar has designed and produced world-class projection lenses since 1978. We offer a wide range of replacement, conversion, fisheye, and custom projection lenses for projectors up to 4K resolution.

Our projection lenses are ideal for corporate and education facilities, planetariums, museums, simulation, immersive environments, and amusement attractions.

Experts in Projection Lens Design:

- Relay and Non-Relay Designs
- Rectilinear and Fisheye Designs
- Fisheye Lenses and F-theta Distortion
- Uniform Pixel Mapping at Image Edge
- Unique Chip Sets, Color Off-Sets
- Panel Size Variations in Light Engines
- Customer Masking Requirements
- Tolerance and Sensitivity Analyses

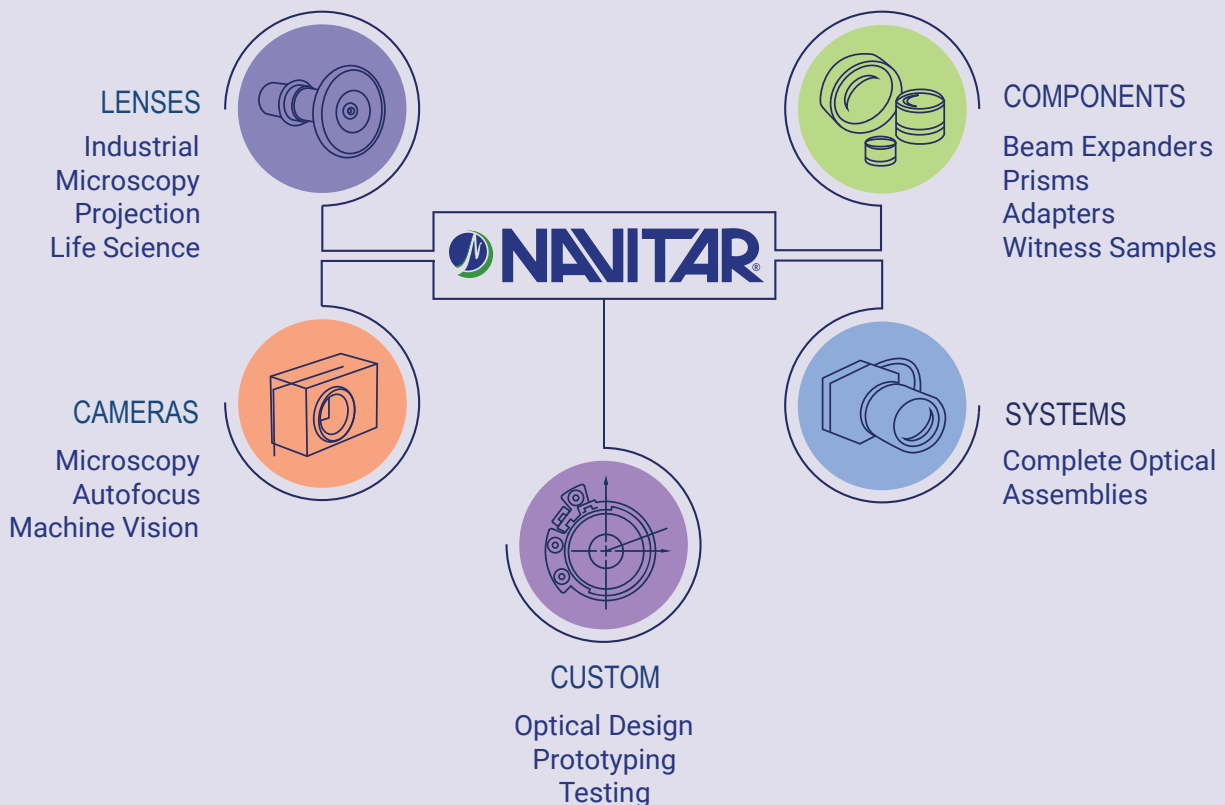

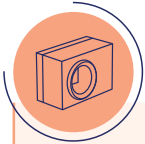

Cameras

Navitar offers fully integrated end-to-end lens and camera imaging solutions to customers worldwide.

Based in Ottawa, Ontario, Canada, Pixelink manufactures, optimizes and integrates industrial cameras for machine vision applications and microscope cameras for life science and digital microscopy applications.



Camera Types:

- USB 3.0
- Board Level
- Autofocus
- USB 2.0
- Enclosed
- HDR
- FireWire
- Trigger
- Polarized
- GigE

Features:

- USB3 Vision Compliant
- High Resolution
- Low Noise Images
- Fast Frame Rates
- One Push Autofocus
- Software Development Kit
- Remote Trigger

Applications:

- Machine Vision
- Inspection
- Medical Imaging
- Metrology
- Biometrics
- Strength Testing
- Microscopy
- Biotechnology
- Virtual Reality
- 3D Object Recognition



Custom Optics

Special Optics designs and manufactures custom microscope objectives for OEMs and researchers who require a solution that is not available off-the-shelf.

Designs span working distances of 0.3mm to 55mm, cover wavelengths from VIS-NIR, can be modified for aqueous, oil and vacuum environments with stainless, ultem or titanium housings.



Custom Objective Application Examples:

- Multi-photon Microscopy
- Cold Fermion/Atom Trapping
- Confocal Microscopy
- STED Microscopy
- Deep Tissues Imaging
- Microscopy and Analysis of Quantum Structures
- Super Resolution Microscopy
- Failure Analysis of Structural Materials
- Live Cell Fluorescent Microscopy
- diSpim Cleared Tissue Imaging

Lens Manufacturing Tolerances:

Attribute	Commercial Quality	Precision Quality	High Precision Quality
Diameter (mm)	+0.00/-0.10	+0.000/-0.05	+0.000/-0.025
Center Thickness (mm)	0.150	0.050	0.005
Radius (power)	8 rings	4 rings	1 ring
Irregularity (waves @633nm)	1	0.25	0.1
Wedge (mm)	0.05	0.005	0.0025
Decenter (arc min)	0.05	0.01	0.005
Scratch-Dig	80-50	60-40	10-5
AR Coating (r avg)	< 1.5%	< 0.5%	< 0.25%



Sensor Integration - Active Alignment

Active alignment of a lens and sensor enables accurate, cost-effective production of high resolution, precision camera modules. The alignment process ensures the full capability of the lens and sensor are carried over to the completed module.

Smaller pixels and larger sensors are driving the need for fast, high resolution lenses. Meeting these high quality demands, yet maintaining a manufacturable lens at a reasonable cost, has forced engineers to employ a variety of techniques to deal with tolerance concerns during lens design. Many times, these manufacturing techniques result in positional accuracies in the single-digit μm range.

Often times, manually attaching a high quality lens to a high quality camera results in a poor to mediocre image due to standard, mechanical attachments such as c-mount or f-mount. The tolerances used for the manufacture of standard mounts, though acceptable for standard imaging, are far too lenient for high resolution applications.

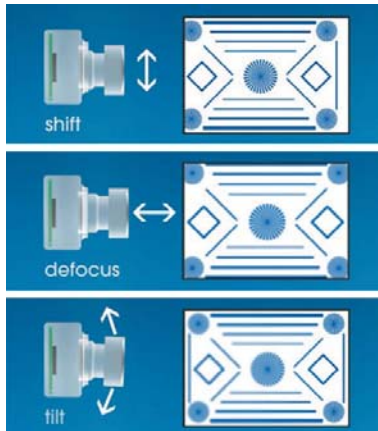

Effects of Misalignment. Image courtesy of Trioptics.

Benefits of Active Sensor Alignment

This is where active alignment comes into the picture. The lens and sensor are aligned while projecting multiple targets through the lens and onto the sensor while the sensor is imaging. The active alignment machine continually monitors the MTF at each of the target images until all MTF values are within acceptable limits.

When all MTF values are acceptable, preapplied adhesive is partially cured using UV, with complete thermal cure performed later. This allows the sensor to be aligned, within micrometers, to the appropriate lens image plane.

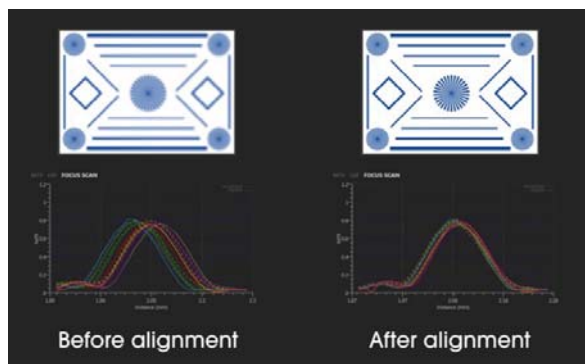

MTF Before and After Alignment. Image courtesy of Trioptics.

Precision Camera Module Production

Navitar 4K HDR lenses offer simple operation, little-to-no focus loss over large temperature ranges, outstanding color correction, and low lens-to-lens variation.

Combining HDR lenses with Pixelink camera sensors allows simple image acquisition (via USB 3.0, GigE, Firewire, etc.) and flexible image processing options to suit your individual application.

Choose from off-the-shelf Navitar 4K HDR lenses and Pixelink camera boards from 2/3" up to 1.1" sensor formats or tailor one of our existing designs to fit your specifications with no time lost during the design process.

Navitar camera modules are used in the automotive, virtual reality, augmented reality, drone, surveillance and agricultural industries.



Active Alignment Position Accuracy Achieved

Specification	
Alignment Degrees of Freedom (DOF) of Sensor	6
Alignment DOF Resolution	< 0.1 μm
Pitch and Roll Accuracy	< 2 arcmin
Yaw Accuracy	< 360 arcsec
Mechanical Lens to Sensor Centration	< 2 μm
Number of Modules Per Hour (MPH)	120 MPH

Contact Navitar's **Sensor Integration** Business Unit for additional information.

Next Generation Zoom Technology

The Resolv4K Lens Series was designed from first order principles to maximize the usage of sensors with higher pixel densities. Numerous adapter options allow users to employ a range of sensors from 1/2" through APS formats and beyond. On the front end of the zoom lens attachments give users the best of both worlds; the low mag end of zoom gives wide fields of view with no sacrifice in MTF or loss of illumination, while the high mag end delivers microscope objective like resolution at extremely long working distances.

The Resolv4K lens has been designed not only for superior visible wavelength axial color correction, but dramatically increased wavelength focusing ability with Visible through Near Infrared (Vis-NIR) and SWIR options. Larger aperture lens attachments significantly increase the usable FOV for coaxial lighting options.



More Throughput

Combining Resolv4K's large field of view and exceptional lens resolution with modern high pixel density sensors results in **faster image capture** of a greater area; making it ideal for high speed inspection and precision measurement applications.

400-600% larger field of view compared to traditional zoom systems

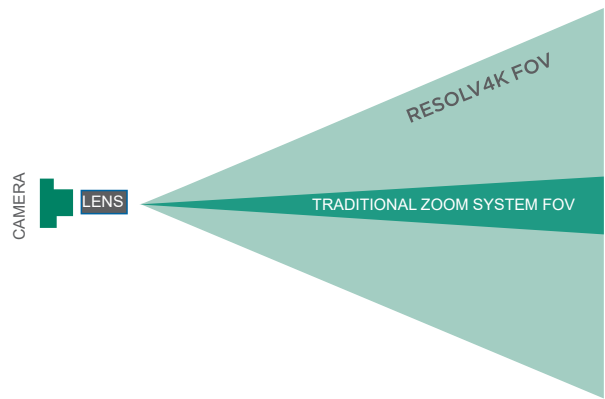

More Wavelengths

Transmission of Resolv4K Coating Options

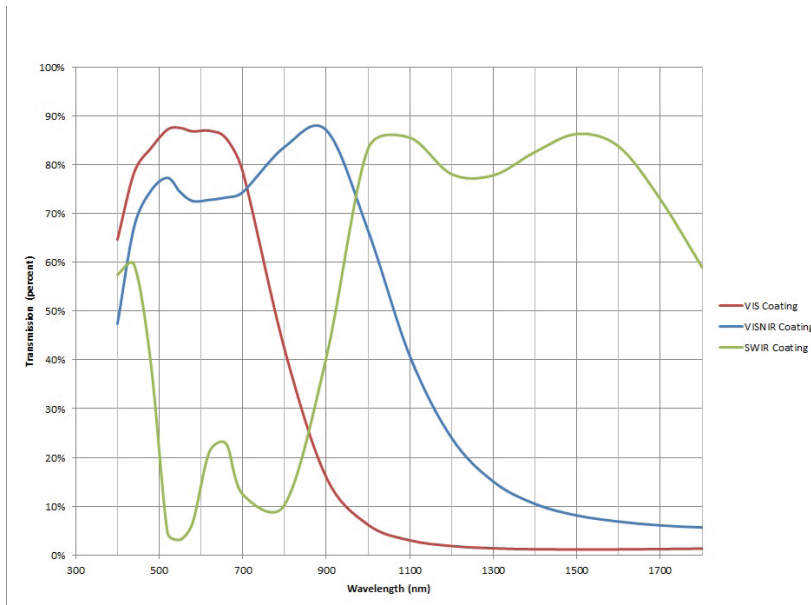

The Resolv4K lens series comes in visible, Vis-NIR and SWIR coating options. The visible options produce superior axial color correction to existing zoom lenses. The Vis-NIR option allows precision surface inspection in the deep blue, while performing sub-surface inspection at 1100nm without refocusing or loss of transmission. Using the SWIR goes even further beneath the surface to see damage and defects, in food and silicon wafer inspection among other applications.

SWIR and Vis-NIR options are available for the following part numbers:

Adapters	Core Zooms and Fixed	Coax	Lens Attachments
1-81101	1-80100	1-81301	1-81201
1-81102	1-80200	1-81303	1-81202
1-81103	1-80300		1-81203
1-81104	1-80500		1-81204
	1-80800		1-81205
			1-81206
			1-81207

Resolv4K Zoom Field of View Matrix (in mm)

Lens Attachment	Rear Adapter Mag		0.6875X	1X	1.375X	2X		
	Ideal Camera Format		2/3"	1"	4/3"	32mm (APS)		
	Pixel Resolution (µm)		2.24 - 5.47	3.26 - 7.95	4.48 - 10.93	6.51 - 15.90	Resolve Limit (µm)	Depth of Field (mm)
	W.D. (mm)	Format	Low-High	Low-High	Low-High	Low-High	Low-High	Low-High
0.25X 0.008 - 0.024 NA 1-81201	359.5	Mag.	0.10X - 0.77X	0.16X - 1.13X	0.22X - 1.55X	0.32X - 2.25X	40.85 - 14.13	7.41 - 0.89
		2/3" Sensor	100.00 - 14.22	68.75 - 9.78	50.00 - 7.11	34.38 - 5.17		
		1" Sensor	-	100.00 - 14.22	72.73 - 10.34	50.00 - 7.11		
		1.1" Sensor	-	110.00 - 15.64	80.00 - 11.38	55.00 - 7.82		
		4/3" Sensor	-	-	100.00 - 14.22	68.75 - 9.78		
		32mm	-	-	-	100.00 - 14.22		
0.5X 0.016 - 0.048 NA 1-81202	173	Mag.	0.22X - 1.55X	0.32X - 2.25X	0.44X - 3.09X	0.64X - 4.50X	20.43 - 7.06	1.85 - 0.22
		2/3" Sensor	50.00 - 7.11	34.38 - 4.89	25.00 - 3.56	17.19 - 2.44		
		1" Sensor	-	50.00 - 7.11	36.36 - 5.17	25.00 - 3.56		
		1.1" Sensor	-	55.00 - 7.82	40.00 - 5.69	27.50 - 3.91		
		4/3" Sensor	-	-	50.00 - 7.11	34.38 - 4.89		
		32mm	-	-	-	50.00 - 7.11		
0.75X 0.025 - 0.071 NA 1-81203	110	Mag.	0.33X - 2.32X	0.48X - 3.38X	0.66X - 4.64X	0.96X - 6.75X	13.62 - 4.71	0.82 - 0.10
		2/3" Sensor	33.33 - 4.74	22.92 - 3.26	16.67 - 2.37	11.46 - 1.63		
		1" Sensor	-	33.33 - 4.74	24.24 - 3.45	16.67 - 2.37		
		1.1" Sensor	-	36.67 - 5.21	26.67 - 3.79	18.33 - 2.61		
		4/3" Sensor	-	-	33.33 - 4.74	22.94 - 3.26		
		32mm	-	-	-	33.33 - 4.74		
1.0X 0.033 - 0.095 NA 1-81204	90	Mag.	0.44X - 3.09X	0.64X - 4.50X	0.88X - 6.19X	1.28X - 9.00X	10.21 - 3.53	0.46 - 0.055
		2/3" Sensor	25.00 - 3.56	17.19 - 2.44	12.50 - 1.78	8.59 - 1.22		
		1" Sensor	-	25.00 - 3.56	18.18 - 2.59	12.50 - 1.78		
		1.1" Sensor	-	27.50 - 3.91	20.00 - 2.84	13.75 - 1.96		
		4/3" Sensor	-	-	25.00 - 3.56	17.19 - 2.44		
		32mm	-	-	-	25.00 - 3.56		
1.25X 0.041 - 0.119 NA 1-81205	72	Mag.	0.55X - 3.87X	0.80X - 5.63X	1.10X - 7.73X	1.60X - 11.25X	8.17 - 2.83	0.30 - 0.035
		2/3" Sensor	20.00 - 2.84	13.75 - 1.96	10.00 - 1.42	6.88 - 0.98		
		1" Sensor	-	20.00 - 2.84	14.55 - 2.07	10.00 - 1.42		
		1.1" Sensor	-	22.00 - 3.13	16.00 - 2.28	11.00 - 1.56		
		4/3" Sensor	-	-	20.00 - 2.84	13.75 - 1.96		
		32mm	-	-	-	20.00 - 2.84		
1.5X 0.049 - 0.142 NA 1-81206	46.5	Mag.	0.66X - 4.64X	0.96X - 6.75X	1.32X - 9.28X	1.92X - 13.50X	6.81 - 2.35	0.206 - 0.025
		2/3" Sensor	16.67 - 2.37	11.46 - 1.63	8.33 - 1.19	5.73 - 0.81		
		1" Sensor	-	16.67 - 2.37	12.12 - 1.72	8.33 - 1.19		
		1.1" Sensor	-	18.33 - 2.61	13.33 - 1.90	9.17 - 1.30		
		4/3" Sensor	-	-	16.67 - 2.37	11.46 - 1.63		
		32mm	-	-	-	16.67 - 2.37		
2.0X 0.066 - 0.190 NA 1-81207	32.3	Mag.	0.88X - 6.19X	1.28X - 9.00X	1.76X - 12.38X	2.56X - 18.00X	5.11 - 1.77	0.116 - 0.014
		2/3" Sensor	12.50 - 1.78	8.59 - 1.22	6.25 - 0.89	4.30 - 0.61		
		1" Sensor	-	12.50 - 1.78	9.09 - 1.29	6.25 - 0.89		
		1.1" Sensor	-	13.75 - 1.96	10.00 - 1.42	6.88 - 0.98		
		4/3" Sensor	-	-	12.50 - 1.78	8.59 - 1.22		
		32mm	-	-	-	12.50 - 1.78		

The above fields of view are measured diagonally in millimeters (Horizontal = Diagonal x 0.8 and Vertical = Diagonal x 0.6) on a 4:3 aspect ratio sensor.
 Dark Gray box: Contact your Navitar sales representative for further guidance when selecting this option.

NOTE: Coax and fine focus options all maintain same FOV, resolution, and working distance, subject to adequate lighting

Resolv4K Field of View Matrix with HR Objectives (mm)

UltraZoom	Objective Lens	Rear Adapter Mag		0.6875X	1X	1.375X	2X	Resolve Limit (µm)	Depth of Field (µm)
		Ideal Camera Format		2/3"	1"	4/3"	32mm (APS)		
		Pixel Resolution (µm)		2.24 - 5.47	3.26 - 7.95	4.48 - 10.93	6.51 - 15.90		
		W.D. (mm)	Format	Low-High	Low-High	Low-High	Low-High		
Navitar 4X 0.066 - 0.190 NA 1-55075	20	Mag.	0.88X - 6.19X	1.28X - 9.00X	1.76X - 12.38X	2.56X - 18.00X	5.11 - 1.77	116 - 14	
		2/3" Sensor	8.10 - 1.78	8.10 - 1.22	6.25 - 0.89	4.30 - 0.61			
		1" Sensor	-	8.10 - 1.78	8.10 - 1.29	6.25 - 0.89			
		1.1" Sensor	-	8.10 - 1.96	8.10 - 1.42	6.88 - 0.98			
		4/3" Sensor	-	-	8.10 - 1.78	8.10 - 1.22			
		32mm	-	-	-	8.10 - 1.78			
Navitar 6X NA 0.099 - 0.285 1-55401	25	Mag.	1.32X - 9.28X	1.92X - 13.50X	2.64X - 18.56X	3.84X - 27.00X	3.40 - 1.18	51 - 6.2	
		2/3" Sensor	6.25 - 1.19	6.25 - 0.81	4.17 - 0.59	2.86 - 0.41			
		1" Sensor	-	6.25 - 1.19	6.25 - 0.86	4.17 - 0.59			
		1.1" Sensor	-	6.25 - 1.30	6.25 - 0.95	4.58 - 0.65			
		4/3" Sensor	-	-	6.25 - 1.19	6.25 - 0.81			
		32mm	-	-	-	6.25 - 1.19			
Navitar 10X 0.164 - 0.400 NA 1-55227	10	Mag.	2.20X - 15.47X	3.20X - 22.50X	4.40X - 30.94X	6.40X - 45.00X	2.04 - 0.84	19 - 3.1	
		2/3" Sensor	3.20 - 0.71	3.20 - 0.49	2.50 - 0.36	1.72 - 0.24			
		1" Sensor	-	3.20 - 0.71	3.20 - 0.52	2.50 - 0.36			
		1.1" Sensor	-	3.20 - 0.78	3.20 - 0.57	2.75 - 0.39			
		4/3" Sensor	-	-	3.20 - 0.71	3.20 - 0.49			
		32mm	-	-	-	3.20 - 0.71			
Mitotoyo 5X 0.082 - 0.140 NA 1-60226	34	Mag.	1.10X - 7.73X	1.60X - 11.25X	2.20X - 15.47X	3.20X - 22.50X	4.09 - 2.40	74.1 - 25.5	
		2/3" Sensor	4.80 - 1.42	4.80 - 0.98	4.80 - 0.71	3.44 - 0.49			
		1" Sensor	-	4.80 - 1.42	4.80 - 1.03	4.80 - 0.71			
		1.1" Sensor	-	4.80 - 1.56	4.80 - 1.14	4.80 - 0.78			
		4/3" Sensor	-	-	4.80 - 1.42	4.80 - 0.98			
		32mm	-	-	-	4.80 - 1.42			
Mitotoyo 10X 0.164 - 0.280 NA 1-60227	33	Mag.	2.20X - 15.47X	3.20X - 22.50X	4.40X - 30.94X	6.40X - 45.00X	2.04 - 1.20	18.5 - 6.4	
		2/3" Sensor	2.40 - 0.71	2.40 - 0.49	2.40 - 0.36	1.72 - 0.24			
		1" Sensor	-	2.40 - 0.71	2.40 - 0.52	2.40 - 0.36			
		1.1" Sensor	-	2.40 - 0.78	2.40 - 0.57	2.40 - 0.39			
		4/3" Sensor	-	-	2.40 - 0.71	2.40 - 0.49			
		32mm	-	-	-	2.40 - 0.71			
Mitotoyo 20X 0.329 - 0.420 NA 1-60228	20	Mag.	4.40X - 30.94X	6.40X - 45.00X	8.80X - 61.88X	12.80X - 90.00X	1.02 - 0.80	4.6 - 2.8	
		2/3" Sensor	1.20 - 0.36	1.20 - 0.24	1.20 - 0.18	0.86 - 0.12			
		1" Sensor	-	1.20 - 0.36	1.20 - 0.26	1.20 - 0.18			
		1.1" Sensor	-	1.20 - 0.39	1.20 - 0.28	1.20 - 0.20			
		4/3" Sensor	-	-	1.20 - 0.36	1.20 - 0.24			
		32mm	-	-	-	1.20 - 0.36			

Fixed	Navitar Objective Lens	Rear Adapter Mag		0.6875X	1X	1.375X	2X	Resolve Limit (µm)	Depth of Field (µm)
		Pixel Resolution (µm)		1.85	2.68	3.69	5.37		
		W.D. (mm)	Format						
4X 0.200 NA 1-55075	20	Mag.	2.20X	3.20X	4.40X	6.40X	1.77	13.75	
		2/3" Sensor	5.00	3.44	2.50	1.72			
		1" Sensor	-	5.00	3.64	2.50			
		1.1" Sensor	-	5.50	4.00	2.75			
		4/3" Sensor	-	-	5.00	3.44			
		APS	-	-	-	5.00			
6X 0.300 NA 1-55401	25	Mag.	3.30X	4.80X	6.60X	9.60X	1.12	6.11	
		2/3" Sensor	3.33	2.29	1.67	1.15			
		1" Sensor	-	3.33	2.42	1.67			
		1.1" Sensor	-	3.67	2.67	1.83			
		4/3" Sensor	-	-	3.33	2.29			
		APS	-	-	-	3.33			
10X 0.400 NA 1-55227	10	Mag.	5.50X	8.00X	11.00X	16.00X	0.70	3.44	
		2/3" Sensor	2.00	1.38	1.00	0.69			
		1" Sensor	-	2.00	1.45	1.00			
		1.1" Sensor	-	2.20	1.60	1.10			
		4/3" Sensor	-	-	2.00	1.38			
		APS	-	-	-	2.00			

Dark Gray box: Contact your Navitar sales representative for further guidance when selecting this option.

More Options

The new Resolv4K Fixed system is a combination of the superb optical performance of the Resolv4K Zoom and design principles of our Precise Eye Fixed that is ideal for fixed field of view applications with closer working distances. The Resolv4K Fixed lens offers higher magnification and resolving power than standard enlarging or SLR lenses in macro mode.

- High apertures improve resolving power by 30% at familiar working distances
- Available interface modules allow users to build their system specifically for their needs
- Standard large camera format options
- Compatible with 10MP cameras and beyond
- Built-in rear adapter fine manipulation focus
- Larger focus options with motorization available
- Compatible with Infinity Corrected Objectives

Resolv4K Fixed Field of View Matrix (in mm at nominal W.D.)

Lens Attachment	Camera Adapter				0.6875X	1X	1.375X	2X
	Pixel Resolution (µm)				1.85	2.68	3.69	5.37
	W.D. (mm)	DOF (mm)	Res. Limit (µm)	Format	Diagonal			
0.25X 0.025 NA 1-81201	359.5	0.88	13.42	Mag.	0.275X	0.40X	0.55X	0.80X
				2/3" Sensor	40.00	27.50	20.00	13.75
				1" Sensor	-	40.00	29.09	20.00
				1.1" Sensor	-	44.00	32.00	22.00
				4/3" Sensor	-	-	40.00	27.50
				APS	-	-	-	40.00
0.5X 0.05 NA 1-81202	173	0.22	6.71	Mag.	0.55X	0.80X	1.10X	1.60X
				2/3" Sensor	20.00	13.75	10.00	6.88
				1" Sensor	-	20.00	14.55	10.00
				1.1" Sensor	-	22.00	16.00	11.00
				4/3" Sensor	-	-	20.00	13.75
				APS	-	-	-	20.00
0.75X 0.075 NA 1-81203	110	0.0978	4.47	Mag.	0.825X	1.20X	1.65X	2.40X
				2/3" Sensor	13.33	9.17	6.67	4.58
				1" Sensor	-	13.33	9.70	6.67
				1.1" Sensor	-	14.67	10.67	7.33
				4/3" Sensor	-	-	13.33	9.17
				APS	-	-	-	13.33
1.0X 0.1 NA 1-81204	90	0.055	3.36	Mag.	1.10X	1.60X	2.20X	3.20X
				2/3" Sensor	10.00	6.88	5.00	3.44
				1" Sensor	-	10.00	7.27	5.00
				1.1" Sensor	-	11.00	8.00	5.50
				4/3" Sensor	-	-	10.00	6.88
				APS	-	-	-	10.00
1.25X 0.125 NA 1-81205	72	0.0352	2.68	Mag.	1.375X	2.00X	2.750X	4.00X
				2/3" Sensor	8.00	5.50	4.00	2.75
				1" Sensor	-	8.00	5.82	4.00
				1.1" Sensor	-	8.80	6.40	4.40
				4/3" Sensor	-	-	8.00	5.50
				APS	-	-	-	8.00
1.5X 0.15 NA 1-81206	46.5	0.0244	2.24	Mag.	1.650X	2.40X	3.30X	4.80X
				2/3" Sensor	6.67	4.58	3.33	2.29
				1" Sensor	-	6.67	4.85	3.33
				1.1" Sensor	-	7.33	5.33	3.67
				4/3" Sensor	-	-	6.67	4.58
				APS	-	-	-	6.67
2X 0.20 NA 1-81207	32.3	0.0138	1.68	Mag.	2.20X	3.20X	4.40X	6.40X
				2/3" Sensor	5.00	3.44	2.50	1.72
				1" Sensor	-	5.00	3.64	2.50
				1.1" Sensor	-	5.50	4.00	2.75
				4/3" Sensor	-	-	5.00	3.44
				APS	-	-	-	5.00

Dark Gray box: Contact your Navitar sales representative for further guidance when selecting this option.

For 4:3 aspect ratio sensor, Horizontal = Diagonal x 0.8, Vertical = Diagonal x 0.6
APS - 32mm image circle

More Field of View

Navitar's Resolv4K Series offers so much more resolving power, that a 400-600% larger field of view is possible when compared to traditional zoom imaging, without any loss of detail. No need to stitch together multiple images from multiple captures.

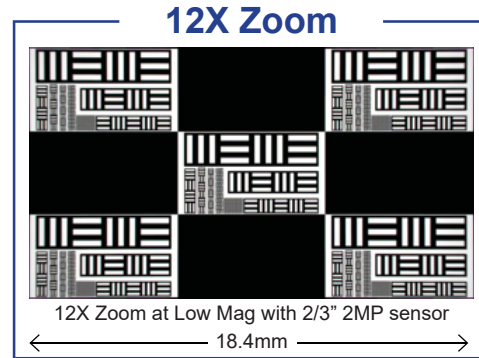

Navitar Resolv4K Zoom

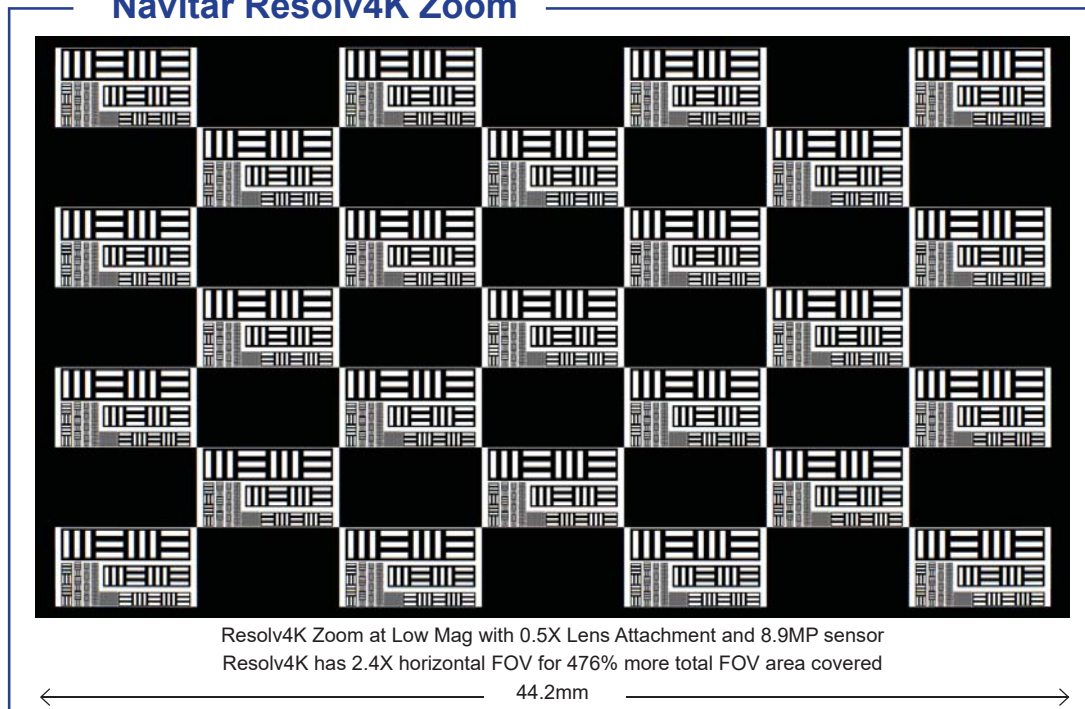

12X Zoom

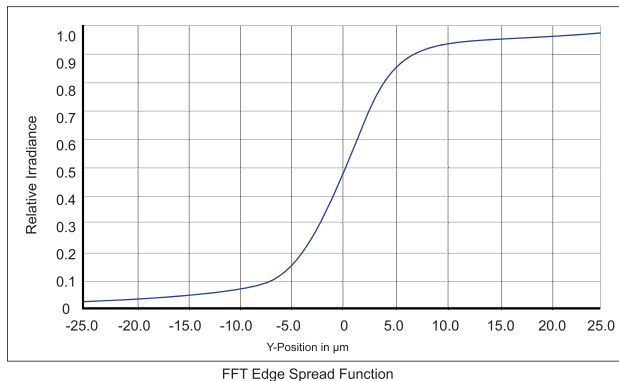

13.6 μ m wide transition from full off to full on.

Navitar Resolv4K Zoom

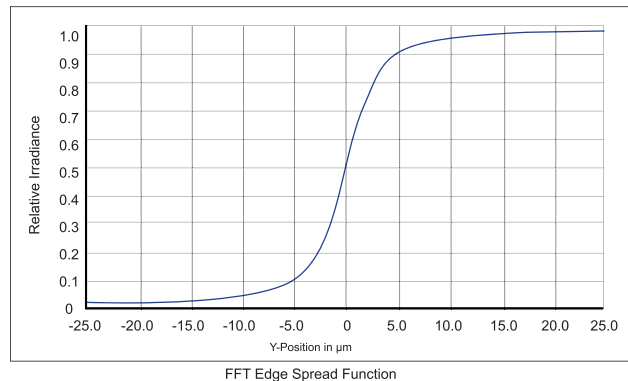

9.6 μ m wide transition from full off to full on, a 30% improvement even at a significantly larger FOV and a longer working distance.

Edge spread functions indicate the lens performance of a system by showing how quickly a black to white edge transition is detected by a lens. A 10% to 90% grey level value at the sensor is shown here as indicating a full off to full on.

More Resolution

Resolv4K's higher NA, along with its superior aberration correction, gives more precise measurement capabilities than ever. Even comparing a 4.5X zoom point to a 7X mag system, the exceptional quality of the Resolv4K design delivers superior performance, as shown in the

black to white transitions in the edge spread functions below. System performance holds up all the way to the corner of the sensor, so multiple regions of interest can be set regardless of their location in your FOV. Your edge detection software will notice the difference.

12X Zoom

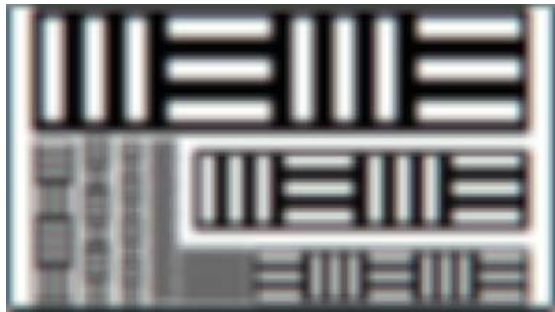

12X Zoom @ 7X High Mag
2MP Sensor – 0.79µm / pixel
1.55mm FOV – 1.28mm² Area

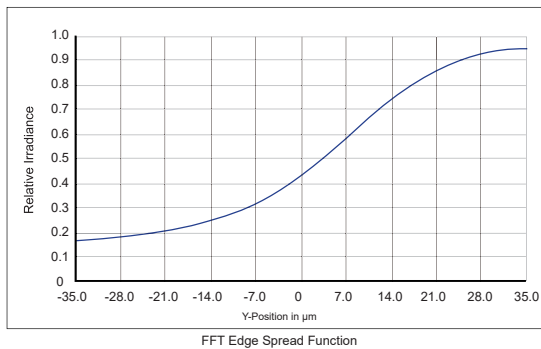
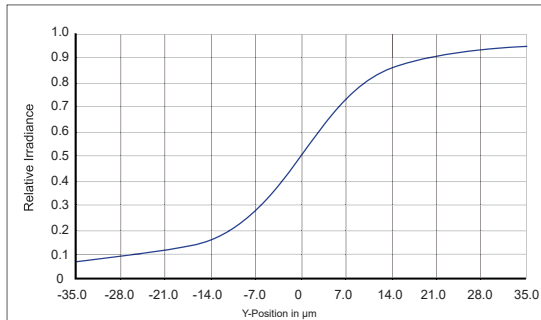

Navitar Resolv4K Zoom



Resolv4K Zoom @ 4.5X High Mag
8.9MP Sensor – 0.76µm / pixel
3.56mm FOV – 5.20mm² Area (3.25X more)

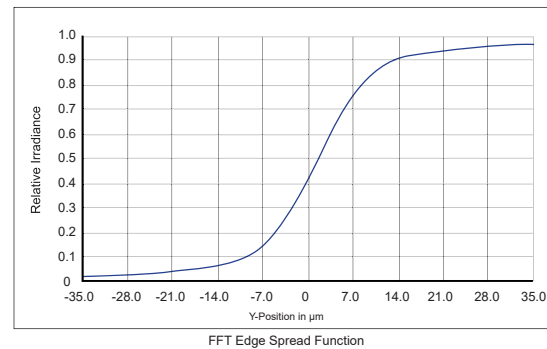
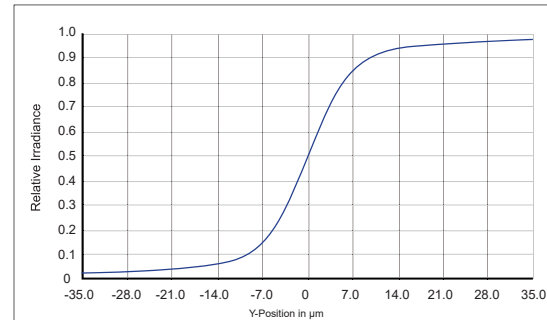

Top Pictures: Zoomed in inset of resolution lines, 0.5µm, 1µm, 2µm, 3µm, 4µm, 6µm, 9µm patterns

Middle Graphs: Edge spread function, on axis

Bottom Graphs: Edge spread function, corner of the sensor

CAMERA MOUNTS

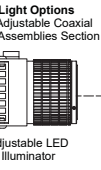
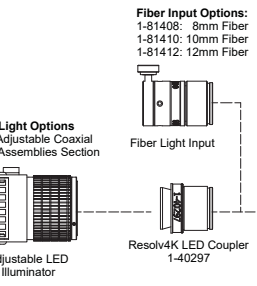
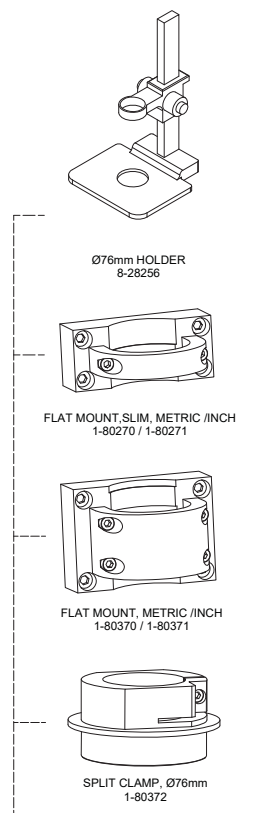
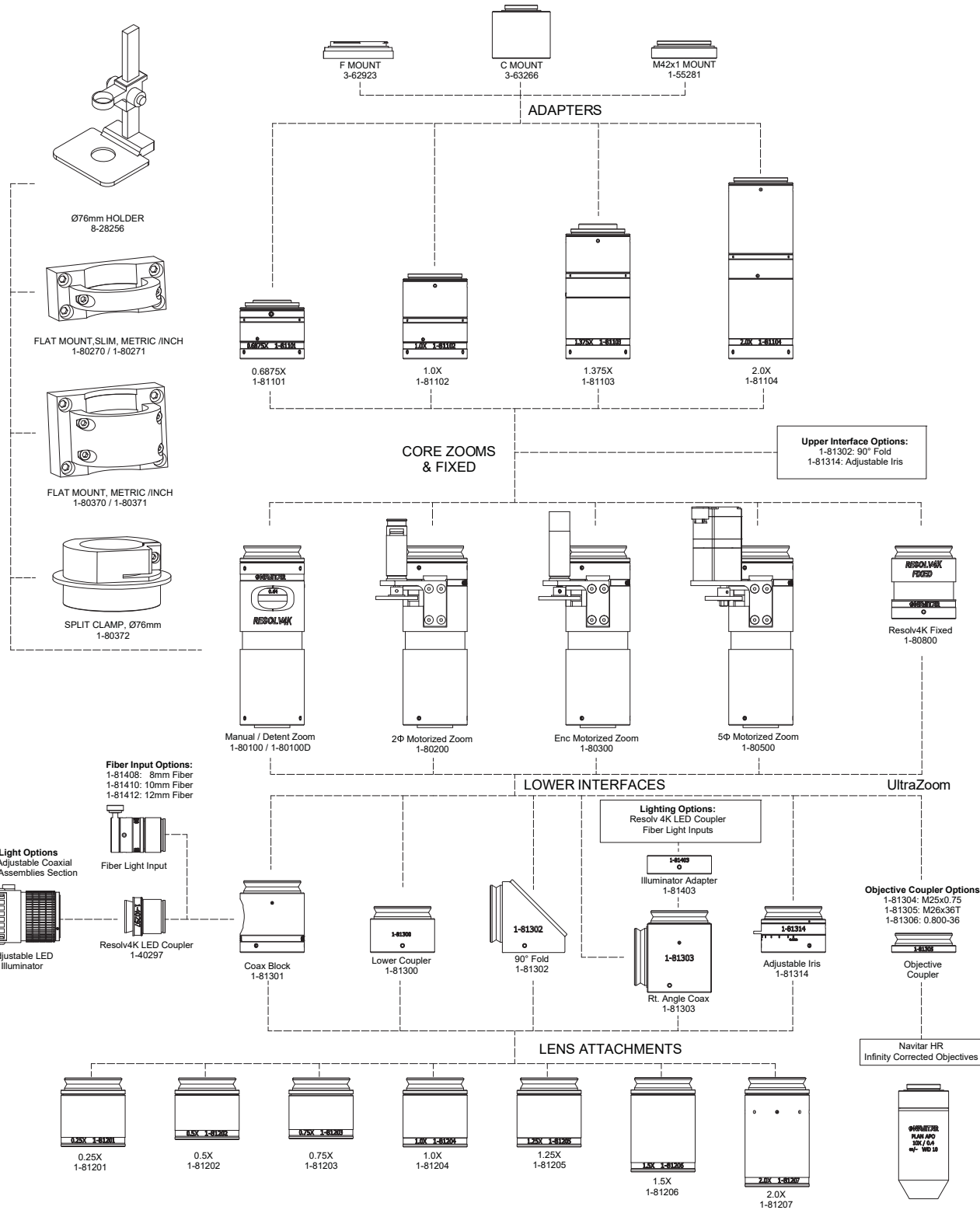

Fine Focus Options on Lens Attachments

M1 Manual FF
 M2 2Φ Motorized FF
 M3 Encoded Motor FF
 M5 5Φ Motorized FF
 e.g. 1-81204M2:
 2Φ Motorized 1X LA

Cable Length	1-80200 (2 phase motor)	1-80300 (encoded motor)	1-80500 (5 phase motor)
24"	1-40283	1-40286	1-40290
48"	1-40282	1-40285	1-40289
72"	1-40281	1-40284	1-40170

Available Adapters

Part #	Description
1-81304	UltraZoom M25x0.75 Adapter
1-81305	UltraZoom M26x36T Adapter Used for all Navitar HR objectives
1-81306	UltraZoom 0.8x36T RMS Adapter

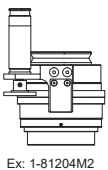

Unmatched Optical Performance

For high magnification applications, the Zoom 6000 series of lenses is the number one choice around the world. Recognized as the industry standard, our versatile 6.5X zoom lenses are designed to give you the magnification powers of traditional microscopes without the bulk or expense. They are easily integrated, assembled, and configured to your exact application. Compared with the competition, the Navitar Zoom 6000 series offers unmatched optical performance, repeatability and mechanical flexibility.

- Dynamic magnification range of 0.09-393.80X offers incredible versatility
- High contrast images and vivid colors help your equipment perform better
- 0.01-182.72 mm field coverage allows you to view a wide range of parts
- Working distance can be varied from 13 to 390 mm
- Add infinity corrected objective lenses to achieve unmatched edge flatness and clarity
- Body tubes with detents, apertures or motorized are available



Zoom 6000 Field of View Matrix (in mm at nominal W.D.)

Lens Attachment	Working Distance (mm)	Camera Format/Parameters	.5X Adapter Low - High	.67X Adapter Low - High	1X Adapter Low - High	1.33X Adapter Low - High	2X Adapter Low - High	3.3X Adapter Low - High	5X Adapter Low - High (2)	Resolve Limit (μm) Low-High	Depth of Field (mm) Low-High
0.25X 0.006 - 0.018 NA 1-6044	300 (nominal)	Mag.	0.09X - 0.56X	0.12X - 0.75X	0.18X - 1.13X	0.24X - 1.50X	0.35X - 2.25X	0.59X - 3.73X	0.88X - 5.62X	55.56 - 18.52	13.89 - 1.54
		1/3" Sensor	68.64 - 10.64	51.12 - 8.04	34.32 - 5.32	25.80 - 4.00	17.16 - 2.66	10.40 - 1.61	6.88 - 1.08	55.56 - 18.52	13.89 - 1.54
	220-390 (1) W.D. range	1/2" Sensor	91.36 - 14.16	68.06 - 10.66	45.68 - 7.08	34.34 - 5.32	22.84 - 3.54	13.84 - 2.14	9.12 - 1.44	55.56 - 18.52	13.89 - 1.54
		2/3" Sensor	91.40 - 19.52	93.62 - 14.66	62.84 - 9.76	47.25 - 7.34	31.42 - 4.88	19.04 - 2.96	12.56 - 1.96	55.56 - 18.52	13.89 - 1.54
		1" Sensor (3)	182.72 - 28.32	136.12 - 21.32	91.36 - 14.16	68.68 - 10.64	45.68 - 7.08	27.68 - 4.28	18.24 - 2.88	55.56 - 18.52	13.89 - 1.54
0.5X 0.011 - 0.035 NA 1-60110	175 (nominal)	Mag.	0.18X - 1.13X	0.24X - 1.50X	0.35X - 2.25X	0.46X - 2.99X	0.70X - 4.50X	1.16X - 7.40X	1.75X - 11.25X	30.30 - 9.52	4.13 - 0.41
		1/3" Sensor	34.32 - 5.32	25.56 - 4.00	17.16 - 2.67	12.90 - 2.01	8.58 - 1.33	5.20 - 0.81	3.43 - 0.53	30.30 - 9.52	4.13 - 0.41
	143-187 (1) W.D. range	1/2" Sensor	45.68 - 7.08	34.03 - 5.33	22.85 - 3.56	17.18 - 2.68	11.42 - 1.77	6.92 - 1.08	4.57 - 0.71	30.30 - 9.52	4.13 - 0.41
		2/3" Sensor	45.70 - 9.76	46.81 - 7.33	31.43 - 4.89	23.63 - 3.68	15.71 - 2.44	9.52 - 1.48	6.29 - 0.98	30.30 - 9.52	4.13 - 0.41
		1" Sensor (3)	91.36 - 14.16	68.06 - 10.66	45.70 - 7.12	34.36 - 5.36	22.84 - 3.54	13.84 - 2.16	9.14 - 1.42	30.30 - 9.52	4.13 - 0.41
0.75X 0.017 - 0.053 NA 1-60111	113 (nominal)	Mag.	0.27X - 1.69X	0.35X - 2.25X	0.53X - 3.38X	0.70X - 4.49X	1.05X - 6.75X	1.75X - 11.15X	2.63X - 16.88X	19.60 - 6.28	1.73 - 0.18
		1/3" Sensor	22.86 - 3.56	17.04 - 2.67	11.43 - 1.78	8.59 - 1.34	5.72 - 0.89	3.46 - 0.54	2.29 - 0.35	19.60 - 6.28	1.73 - 0.18
	100-119 (1) W.D. range	1/2" Sensor	30.46 - 4.74	22.69 - 3.56	15.23 - 2.37	11.45 - 1.78	7.62 - 1.19	4.62 - 0.72	3.05 - 0.47	19.60 - 6.28	1.73 - 0.18
		2/3" Sensor	30.50 - 6.52	31.21 - 4.89	20.95 - 3.26	15.75 - 2.45	10.48 - 1.63	6.35 - 0.99	4.19 - 0.65	19.60 - 6.28	1.73 - 0.18
		1" Sensor (3)	60.92 - 9.48	45.38 - 7.12	30.46 - 4.74	22.90 - 3.56	15.24 - 2.38	9.24 - 1.44	6.10 - 0.94	19.60 - 6.28	1.73 - 0.18
None 0.023 - 0.071 NA	92 (nominal)	Mag.	0.35X - 2.25X	0.47X - 3.00X	0.70X - 4.50X	0.93X - 5.89X	1.40X - 9.00X	2.31X - 14.85X	3.50X - 22.50X	14.5 - 4.70	0.95 - 0.10
		1/3" Sensor	17.16 - 2.67	12.77 - 2.01	8.58 - 1.33	6.45 - 1.00	4.29 - 0.67	2.60 - 0.40	1.72 - 0.27	14.5 - 4.70	0.95 - 0.10
	81-93 (1) W.D. range	1/2" Sensor	22.85 - 3.56	17.01 - 2.67	11.42 - 1.77	8.59 - 1.33	5.71 - 0.89	3.46 - 0.54	2.28 - 0.36	14.5 - 4.70	0.95 - 0.10
		2/3" Sensor	22.90 - 4.89	23.40 - 3.65	15.71 - 2.44	11.81 - 1.83	7.86 - 1.22	4.76 - 0.74	3.14 - 0.49	14.5 - 4.70	0.95 - 0.10
		1" Sensor (3)	45.70 - 7.12	34.02 - 5.34	22.84 - 3.54	17.18 - 2.66	11.42 - 1.78	6.92 - 1.08	4.56 - 0.72	14.5 - 4.70	0.95 - 0.10
1.5X 0.034 - 0.106 NA 1-60112	51 (nominal)	Mag.	0.53X - 3.38X	0.71X - 4.50X	1.05X - 6.75X	1.40X - 8.98X	2.10X - 13.50X	3.47X - 22.28X	5.25X - 33.75X	9.80 - 3.14	0.43 - 0.04
		1/3" Sensor	11.43 - 1.78	8.52 - 1.33	5.72 - 0.89	4.3 - 0.67	2.86 - 0.44	1.73 - 0.27	1.14 - 0.18	9.80 - 3.14	0.43 - 0.04
	48-52 (1) W.D. range	1/2" Sensor	15.23 - 2.37	11.34 - 1.77	7.62 - 1.19	5.73 - 0.89	3.81 - 0.59	2.31 - 0.36	1.52 - 0.24	9.80 - 3.14	0.43 - 0.04
		2/3" Sensor	15.00 - 3.26	15.60 - 2.44	10.48 - 1.63	7.88 - 1.22	5.24 - 0.81	3.18 - 0.49	2.10 - 0.33	9.80 - 3.14	0.43 - 0.04
		1" Sensor (3)	30.46 - 4.74	22.68 - 3.54	15.24 - 2.38	11.46 - 1.78	7.62 - 1.18	4.62 - 0.72	3.04 - 0.48	9.80 - 3.14	0.43 - 0.04
2.0X 0.040 - 0.142 NA 1-60113	36 (nominal)	Mag.	0.70X - 4.50X	0.94X - 6.00X	1.40X - 9.00X	1.86X - 11.97X	2.80X - 18.00X	4.62X - 29.70X	7.00X - 45.00X	7.24 - 2.34	0.24 - 0.02
		1/3" Sensor	8.58 - 1.33	6.39 - 1.00	4.29 - 0.67	3.22 - 0.50	2.15 - 0.33	1.30 - 0.14	0.86 - 0.13	7.24 - 2.34	0.24 - 0.02
	34-37 (1) W.D. range	1/2" Sensor	11.42 - 1.77	8.51 - 1.33	5.71 - 0.89	4.29 - 0.67	2.86 - 0.44	1.73 - 0.27	1.14 - 0.18	7.24 - 2.34	0.24 - 0.02
		2/3" Sensor	11.40 - 2.44	11.70 - 1.83	7.86 - 1.22	5.91 - 0.92	3.93 - 0.61	2.38 - 0.37	1.57 - 0.24	7.24 - 2.34	0.24 - 0.02
		1" Sensor (3)	22.84 - 3.54	17.02 - 2.66	11.42 - 1.78	8.58 - 1.34	5.72 - 0.88	3.46 - 0.54	2.24 - 0.36	7.24 - 2.34	0.24 - 0.02

The above fields of view are measured diagonally in millimeters (Horizontal = Diagonal x 0.8 and Vertical = Diagonal x 0.6).

(1) Working distance range when using 12 mm fine focus. Field of view will change with shorter or longer working distances.

(2) When using 5X Adapter image quality is greatly reduced. Contact your Navitar sales representative for detailed specifications.

(3) All systems using a 1" sensor should be discussed with a Navitar applications expert.

NA varies depending on system magnification.

Zoom 6000 Performance Specifications

Zoom 6000 Combinations Lens Attachment + Prime Lens + Adapter	Working Distance (mm)	System	NA Objective	Resolve Limit	Matching Pixel	Depth of Field (mm)
		Magnification Low-High	Low-High	(μ m) Low-High	Size (μ m) Low-High	Low-High
0.25x + 6.5X Zoom + 0.5x	300	0.09 - 0.56	0.006 - 0.018	55.56 - 18.52	2.50 - 5.19	13.89 - 1.54
0.25x + 6.5X Zoom + 0.67x	300	0.12 - 0.75	0.006 - 0.018	55.56 - 18.52	3.33 - 6.95	13.89 - 1.54
0.25x + 6.5X Zoom + 1.0x	300	0.18 - 1.13	0.006 - 0.018	55.56 - 18.52	5.00 - 10.46	13.89 - 1.54
0.25x + 6.5X Zoom + 1.33x	300	0.23 - 1.51	0.006 - 0.018	55.56 - 18.52	6.65 - 13.91	13.89 - 1.54
0.25x + 6.5X Zoom + 2.0x	300	0.35 - 2.25	0.006 - 0.018	55.56 - 18.52	9.72 - 20.84	13.89 - 1.54
0.25x + 6.5X Zoom + 3.3x	300	0.58 - 3.71	0.006 - 0.018	55.56 - 18.52	15.29 - 28.93	13.89 - 1.54
0.25x + 6.5X Zoom + 5.0x	300	0.88 - 5.62	0.006 - 0.018	55.56 - 18.52	24.45 - 52.04	13.89 - 1.54
0.5x + 6.5X Zoom + 0.5x	175	0.18 - 1.13	0.011 - 0.035	30.30 - 9.52	2.73 - 5.38	4.13 - 0.41
0.5x + 6.5X Zoom + 0.67x	175	0.23 - 1.50	0.011 - 0.035	30.30 - 9.52	3.48 - 7.14	4.13 - 0.41
0.5x + 6.5X Zoom + 1.0x	175	0.35 - 2.25	0.011 - 0.035	30.30 - 9.52	5.30 - 10.71	4.13 - 0.41
0.5x + 6.5X Zoom + 1.33x	175	0.47 - 3.03	0.011 - 0.035	30.30 - 9.52	7.05 - 14.24	4.13 - 0.41
0.5x + 6.5X Zoom + 2.0x	175	0.70 - 4.50	0.011 - 0.035	30.30 - 9.52	10.61 - 21.42	4.13 - 0.41
0.5x + 6.5X Zoom + 3.3x	175	1.16 - 7.43	0.011 - 0.035	30.30 - 9.52	15.44 - 39.08	4.13 - 0.41
0.5x + 6.5X Zoom + 5.0x	175	1.75 - 11.25	0.011 - 0.035	30.30 - 9.52	26.51 - 53.55	4.13 - 0.41
0.75x + 6.5X Zoom + 0.5x	113	0.26 - 1.69	0.017 - 0.053	19.62 - 6.28	2.55 - 5.32	1.73 - 0.18
0.75x + 6.5X Zoom + 0.67x	113	0.35 - 2.25	0.017 - 0.053	19.62 - 6.28	3.43 - 7.08	1.73 - 0.18
0.75x + 6.5X Zoom + 1.0x	113	0.53 - 3.38	0.017 - 0.053	19.62 - 6.28	5.20 - 10.63	1.73 - 0.18
0.75x + 6.5X Zoom + 1.33x	113	0.70 - 4.54	0.017 - 0.053	19.62 - 6.28	6.92 - 14.13	1.73 - 0.18
0.75x + 6.5X Zoom + 2.0x	113	1.05 - 6.75	0.017 - 0.053	19.62 - 6.28	10.30 - 21.23	1.73 - 0.18
0.75x + 6.5X Zoom + 3.3x	113	1.73 - 11.14	0.017 - 0.053	19.62 - 6.28	15.36 - 33.31	1.73 - 0.18
0.75x + 6.5X Zoom + 5.0x	113	2.63 - 16.88	0.017 - 0.053	19.62 - 6.28	25.74 - 53.09	1.73 - 0.18
None + 6.5X Zoom + 0.5x	92	0.35 - 2.25	0.023 - 0.071	14.50 - 4.70	2.54 - 5.28	0.95 - 0.10
None + 6.5X Zoom + 0.67x	92	0.47 - 3.00	0.023 - 0.071	14.50 - 4.70	3.41 - 7.04	0.95 - 0.10
None + 6.5X Zoom + 1.0x	92	0.70 - 4.50	0.023 - 0.071	14.50 - 4.70	5.08 - 10.55	0.95 - 0.10
None + 6.5X Zoom + 1.33x	92	0.93 - 6.05	0.023 - 0.071	14.50 - 4.70	6.76 - 14.03	0.95 - 0.10
None + 6.5X Zoom + 2.0x	92	1.40 - 9.00	0.023 - 0.071	14.50 - 4.70	10.15 - 21.11	0.95 - 0.10
None + 6.5X Zoom + 3.3x	92	2.31 - 14.85	0.023 - 0.071	14.50 - 4.70	15.29 - 29.11	0.95 - 0.10
None + 6.5X Zoom + 5.0x	92	3.50 - 22.50	0.023 - 0.071	14.50 - 4.70	25.38 - 52.76	0.95 - 0.10
1.5x + 6.5X Zoom + 0.5x	51	0.53 - 3.38	0.034 - 0.106	9.80 - 3.14	2.60 - 5.32	0.43 - 0.04
1.5x + 6.5X Zoom + 0.67x	51	0.70 - 4.50	0.034 - 0.106	9.80 - 3.14	3.43 - 7.09	0.43 - 0.04
1.5x + 6.5X Zoom + 1.0x	51	1.05 - 6.75	0.034 - 0.106	9.80 - 3.14	5.15 - 10.63	0.43 - 0.04
1.5x + 6.5X Zoom + 1.33	51	1.40 - 9.08	0.034 - 0.106	9.80 - 3.14	6.85 - 14.14	0.43 - 0.04
1.5x + 6.5X Zoom + 2.0x	51	2.10 - 13.50	0.034 - 0.106	9.80 - 3.14	10.29 - 21.26	0.43 - 0.04
1.5x + 6.5X Zoom + 3.3x	51	3.47 - 22.28	0.034 - 0.106	9.80 - 3.14	15.29 - 28.92	0.43 - 0.04
1.5x + 6.5X Zoom + 5.0x	51	5.25 - 33.75	0.034 - 0.106	9.80 - 3.14	25.73 - 53.16	0.43 - 0.04
2.0x + 6.5X Zoom + 0.5x	36	0.70 - 4.50	0.046 - 0.142	7.24 - 2.34	2.54 - 5.29	0.24 - 0.02
2.0x + 6.5X Zoom + 0.67x	36	0.94 - 6.00	0.046 - 0.142	7.24 - 2.34	3.41 - 7.05	0.24 - 0.02
2.0x + 6.5X Zoom + 1.0x	36	1.40 - 9.00	0.046 - 0.142	7.24 - 2.34	5.08 - 10.58	0.24 - 0.02
2.0x + 6.5X Zoom + 1.33	36	1.86 - 12.10	0.046 - 0.142	7.24 - 2.34	6.76 - 14.07	0.24 - 0.02
2.0x + 6.5X Zoom + 2.0x	36	2.80 - 18.00	0.046 - 0.142	7.24 - 2.34	10.15 - 21.15	0.24 - 0.02
2.0x + 6.5X Zoom + 3.3x	36	4.62 - 29.70	0.046 - 0.142	7.24 - 2.34	15.30 - 28.70	0.24 - 0.02
2.0x + 6.5X Zoom + 5.0x	36	7.00 - 45.00	0.046 - 0.142	7.24 - 2.34	25.38 - 52.88	0.24 - 0.02

Assumptions:

1. Minimum resolvable feature size is half of the threshold line pair limit. Calculation = $1/(3000 \times \text{Lens NA})$
2. Matching pixel size is that which will permit the minimum feature size to overlap two pixels. Calculation = $1/2(\text{Feature Size} \times \text{System Magnification})$
3. If the matching pixel size is greater than the camera pixel size, the system is "lens limited."
4. If the matching pixel size is less than the camera pixel size, the system is "camera limited."

Combine Infinity-Corrected Objectives for Maximum Resolution and Magnification

Navitar's UltraZoom is ideal for semiconductor inspection, flow cytometry, and other high magnification applications. Its advanced design offers high resolution and outstanding contrast. This system incorporates infinity corrected, plan apochromatic objectives providing long working distances and excellent edge flatness and clarity. Resolution varies from 420 to 1,650 lines per mm, depending on the microscope objective used. The UltraZoom is also available with fine focus and/or coaxial illumination.



Zoom 6000 UltraZoom Field of View Matrix
(for part number's 1-60190, 1-60191, 1-60349 and 1-60350 in mm)

Objective Lens Long W.D	Working Distance (mm)	Camera Format/ Parameters	1X Adapter Low - High	1.33X Adapter Low - High	2X Adapter Low - High	3.3X Adapter Low - High
4X 0.20 NA* 1-55341	20	Mag.	1.99X - 9.14X	1.79X - 12.16X	2.78X - 18.29X	4.59X - 30.18X
		1/4" Sensor	2.01 - 0.44	2.24 - 0.33	1.44 - 0.22	0.87 - 0.13
		1/3" Sensor	3.02 - 0.66	3.35 - 0.49	2.16 - 0.33	1.31 - 0.20
		1/2" Sensor	(1) 5.15 - 0.87	4.47 - 0.66	2.87 - 0.44	1.74 - 0.27
		2/3" Sensor	(1) 5.15 - 1.20	6.15 - 0.90	3.95 - 0.60	2.39 - 0.36
5X 0.14 NA* 1-60226	34	Mag.	1.74X - 11.43X	2.30X - 15.00X	3.48X - 22.86X	5.74X - 37.72X
		1/4" Sensor	2.30 - 0.35	1.74 - 0.26	1.15 - 0.17	0.70 - 0.11
		1/3" Sensor	3.45 - 0.52	2.61 - 0.40	1.72 - 0.26	1.04 - 0.16
		1/2" Sensor	(1) 4.05 - 0.70	3.48 - 0.54	2.30 - 0.35	1.39 - 0.21
		2/3" Sensor	(1) 4.02 - 0.96	4.00 - 0.74	3.16 - 0.48	1.92 - 0.29
10X 0.28 NA* 1-60227	33	Mag.	3.48X - 22.86X	4.63X - 29.90X	6.96X - 45.72X	11.48X - 75.44X
		1/4" Sensor	1.15 - 0.17	0.86 - 0.13	0.57 - 0.09	0.35 - 0.05
		1/3" Sensor	1.72 - 0.26	1.30 - 0.20	0.86 - 0.13	0.52 - 0.08
		1/2" Sensor	(1) 2.10 - 0.35	1.73 - 0.27	1.15 - 0.17	0.70 - 0.11
		2/3" Sensor	(1) 2.10 - 0.48	2.10 - 0.37	1.58 - 0.24	0.96 - 0.15
20X 0.42 NA* 1-60228	20	Mag.	6.96X - 45.72X	9.30X - 59.90X	13.92X - 91.40X	22.97X - 150.88X
		1/4" Sensor	0.57 - 0.09	0.43 - 0.07	0.29 - 0.04	0.17 - 0.03
		1/3" Sensor	0.86 - 0.13	0.65 - 0.10	0.43 - 0.07	0.26 - 0.04
		1/2" Sensor	(1) 1.00 - 0.17	0.86 - 0.14	0.57 - 0.09	0.35 - 0.05
		2/3" Sensor	(1) 1.03 - 0.24	1.00 - 0.19	0.79 - 0.12	0.48 - 0.07
50X 0.55 NA* 1-60229	13	Mag.	17.40X - 114.30X	23.00X-150.00X	34.80X - 228.60X	57.42X - 377.19X
		1/4" Sensor	0.23 - 0.03	0.17 - 0.03	0.11 - 0.02	0.07 - 0.011
		1/3" Sensor	0.30 - 0.05	0.26 - 0.04	0.17 - 0.03	0.10 - 0.020
		1/2" Sensor	(1) 0.31 - 0.07	0.30 - 0.05	0.23 - 0.04	0.14 - 0.020
		2/3" Sensor	(1) 0.30 - 0.10	(1) 0.30 - 0.07	(1) 0.30 - 0.05	0.19 - 0.030

NOTE: (1) Entire zoom range is not used. *NA at high mag . NA varies with zoom settings.

Zoom 6000™ with Co-axial Illumination

Navitar's Zoom 6000 with Internal Co-axial Illumination (1-60123) is an ideal solution for applications involving highly reflective surfaces, such as wafers, polished samples, and fluids. Designed to provide even illumination for higher magnification applications, coaxial illumination provides extremely detailed resolution, particularly when a high resolution camera is used.

Zoom 6000 with Co-axial Illumination Field of View Matrix 1-60123 (in mm at nominal W.D.)

Lens Attachment	W.D. (mm)	Camera Format/Parameters	.5X Adapter Low - High	.67X Adapter Low - High	1X Adapter Low - High	1.33X Adapter Low - High	2X Adapter Low - High	3.3X Adapter Low - High	5X Adapter Low - High
None 0.023-0.071 NA	92 (nominal)	Mag.	0.35X - 2.25X	0.47X - 3.00X	0.70X - 4.50X	0.93X - 6.00X	1.40X - 9.00X	2.45X - 15.75X	3.50X - 22.50X
		1/4" Sensor	11.43 - 1.78	8.51 - 1.33	5.71 - 0.89	4.30X - 0.67	2.86 - 0.45	1.63 - 0.25	1.14 - 0.18
	90-93 (1) W.D. range	1/3" Sensor	(2) 11.10 - 2.67	(2) 11.40 - 2.01	8.58 - 1.33	6.45 - 1.00	4.29 - 0.67	2.45 - 0.38	1.72 - 0.27
		1/2" Sensor	(2) 11.20 - 3.56	(2) 11.46 - 2.62	11.42 - 1.77	8.60 - 1.33	5.71 - 0.89	3.27 - 0.51	2.28 - 0.36
		2/3" Sensor	(2) 11.06 - 4.89	(2) 11.54 - 3.60	11.40 - 2.44	11.00 - 1.83	7.86 - 1.22	4.49 - 0.70	3.14 - 0.49
1.5X 0.034-0.106 NA 1-60112	51 (nominal)	Mag.	0.53X - 3.38X	0.71X - 4.50X	1.05X - 6.75X	1.40X - 9.00X	2.10X - 13.50X	3.70X - 23.60X	5.25X - 33.75X
		1/4" Sensor	7.62 - 1.18	5.67 - 0.89	3.81 - 0.59	2.85 - 0.44	1.91 - 0.30	1.08 - 0.17	0.76 - 0.120
	51-53 (1) W.D. range	1/3" Sensor	11.32 - 1.78	8.52 - 1.33	5.72 - 0.89	4.29 - 0.67	2.86 - 0.44	1.62 - 0.25	1.14 - 0.18
		1/2" Sensor	(2) 11.20 - 2.37	11.34 - 1.77	7.62 - 1.19	5.71 - 0.89	3.81 - 0.59	2.16 - 0.34	1.52 - 0.24
		2/3" Sensor	(2) 11.20 - 3.25	(2) 11.20 - 2.44	10.48 - 1.63	7.86 - 1.22	5.24 - 0.81	2.97 - 0.47	2.10 - 0.33
2.0X 0.046-0.1421 NA 1-60113	36 (nominal)	Mag.	0.70X - 4.50X	0.94X - 6.00X	1.40X - 9.00X	1.86X-12.00X	2.80X - 18.00X	4.90X-31.50X	7.00X - 45.00X
		1/4" Sensor	5.71 - 0.89	4.26 - 0.67	2.86 - 0.45	2.15 - 0.33	1.43 - 0.23	0.82 - 0.13	0.57 - 0.09
	36-37 (1) W.D. range	1/3" Sensor	8.57 - 1.33	6.39 - 1.00	4.29 - 0.67	3.22 - 0.50	2.15 - 0.33	1.22 - 0.19	0.86 - 0.13
		1/2" Sensor	(2) 11.20 - 1.77	8.51 - 1.33	5.71 - 0.89	4.30 - 0.67	2.86 - 0.44	1.63 - 0.25	1.14 - 0.18
		2/3" Sensor	(2) 11.20 - 2.44	(2) 11.70 - 1.83	7.86 - 1.22	5.91 - 0.92	3.93 - 0.61	2.24 - 0.35	1.57 - 0.24

NOTE:

The internal coax will illuminate a circular area of about 11 mm in diameter. Any field of view larger than 11 mm will have darkened corners.

Low power lens attachments can be used but produce increasing vignetting.

(1) Working distance range when using 3 mm fine focus.

(2) Entire zoom range is not used.

ZOOM 6000 SYSTEM DIAGRAM

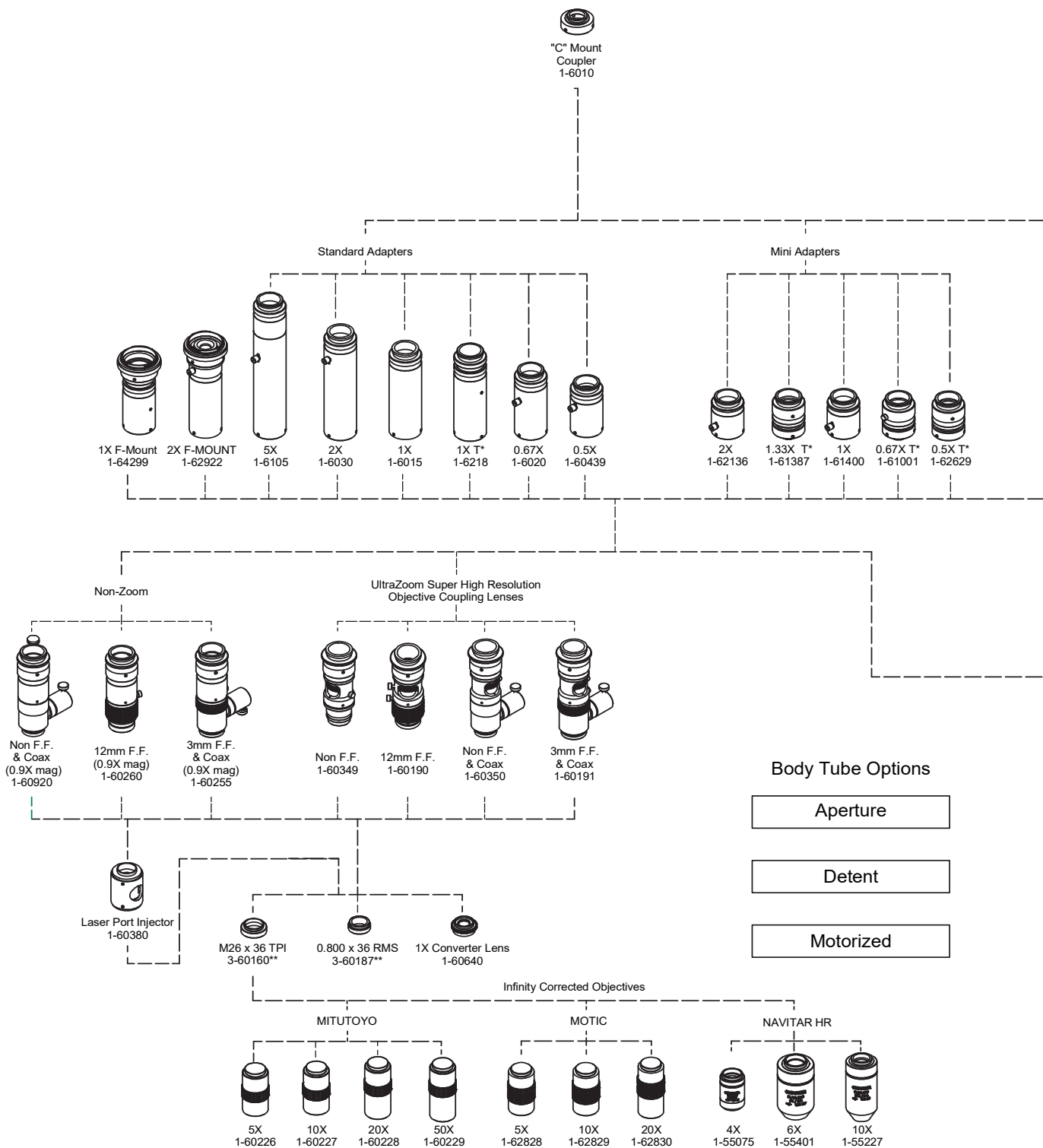

*T = Tele
 ** Included with UltraZoom
 *** Not Used with Internal Coaxial

ZOOM 6000 SYSTEM DIAGRAM

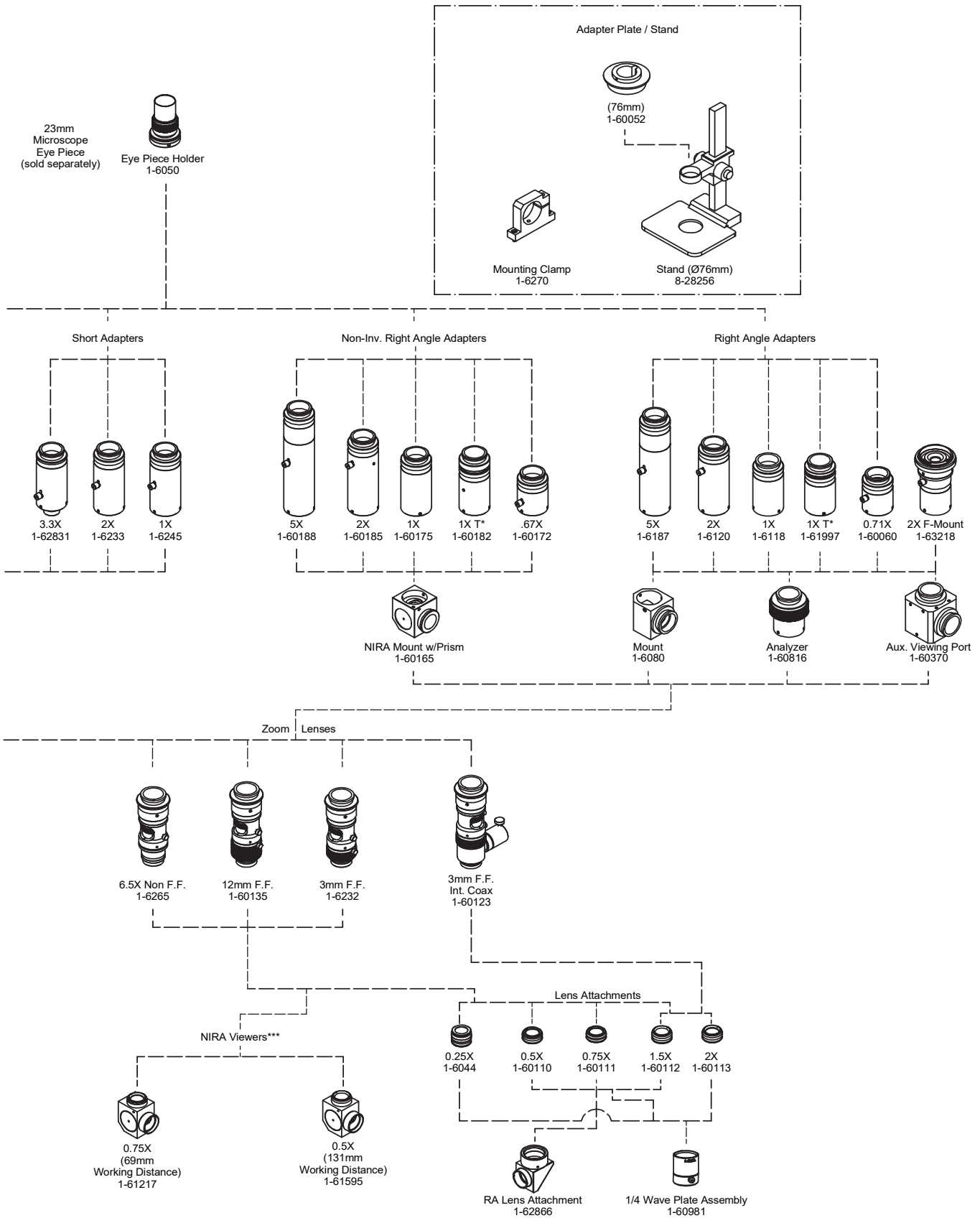

OPTOTUNE LIQUID LENS

Gain greater working distance and faster focus by integrating a tunable lens focus module with the Navitar Zoom 6000 digital imaging system.

Key Features

- Fast and accurate fine focus adjustment in a compact design
- Extends working distance range of the 6X lens attachments
- Increases depth of field when coupled with infinity corrected microscope objectives
- Maintains image resolution with the integrated Optotune EL 16-40 tunable lens
- Long cycle life of the tunable lens unit and motorized Zoom 6000 system
- Easy to install USB electrical lens driver with software to control the tunable lens



Optotune Module (Navitar 1-64805) with Zoom 6000 Motorized System

Zoom 6000 with Optotune - Additional Working Distances

Lens Attachment	Optotune Power (Diopters)	Working Distance (mm)	Magnification		Object NA		Resolve Limit (μm)	
			Low Mag	High Mag	Low Mag	High Mag	Low Mag	High Mag
0.25X 1-6044	-2	2260.3	0.026	0.166	0.001	0.003	383.59	146.32
	-1	531.1	0.104	0.673	0.004	0.012	94.91	32.37
	0	288.8	0.183	1.173	0.007	0.021	54.15	20.30
	1	191.3	0.262	1.686	0.009	0.030	37.85	19.26
	2	139.1	0.341	2.202	0.012	0.038	29.06	14.30
	3	106.3	0.421	2.742	0.015	0.047	24.77	11.12
0.5X 1-60110	-2	301.4	0.212	1.348	0.008	0.024	47.14	16.86
	-1	222.9	0.277	1.751	0.010	0.031	36.41	13.60
	0	174.0	0.343	2.168	0.012	0.039	28.84	10.73
	1	140.8	0.409	2.587	0.015	0.046	23.95	10.17
	2	116.8	0.475	3.003	0.017	0.054	20.83	12.33
	3	98.6	0.542	3.441	0.019	0.061	18.46	9.69
0.75X 1-60111	-2	152.8	0.410	2.635	0.015	0.046	24.13	9.26
	-1	128.8	0.470	3.009	0.017	0.053	20.85	7.38
	0	110.1	0.530	3.389	0.019	0.060	18.48	6.42
	1	95.3	0.591	3.760	0.021	0.067	16.76	6.03
	2	83.2	0.651	4.151	0.023	0.073	15.35	8.01
	3	73.1	0.712	4.567	0.026	0.080	14.18	7.81
1.0X None	-2	116.6	0.590	3.803	0.021	0.066	16.63	6.57
	-1	104.4	0.644	4.144	0.023	0.072	15.38	5.36
	0	94.0	0.698	4.503	0.025	0.078	14.19	4.85
	1	85.2	0.752	4.835	0.027	0.085	13.16	4.81
	2	77.5	0.807	5.199	0.029	0.091	12.52	6.01
	3	70.8	0.862	5.590	0.031	0.097	11.96	6.17
1.5X 1-60112	-2	58.1	0.956	6.210	0.034	0.107	10.57	4.24
	-1	53.3	1.004	6.481	0.036	0.112	9.86	3.51
	0	48.9	1.053	6.760	0.038	0.118	9.40	3.22
	1	44.9	1.102	7.047	0.039	0.123	8.90	3.46
	2	41.3	1.151	7.372	0.041	0.129	8.69	4.84
	3	37.9	1.201	7.745	0.043	0.134	8.50	4.30
2X 1-60113	-2	41.1	1.309	8.473	0.047	0.146	7.79	3.28
	-1	38.5	1.347	8.658	0.048	0.150	7.35	2.69
	0	36.0	1.386	8.864	0.050	0.155	7.08	2.45
	1	33.7	1.424	9.084	0.051	0.159	6.95	2.50
	2	31.4	1.463	9.358	0.052	0.163	6.90	3.95
	3	29.3	1.503	9.694	0.054	0.167	7.01	3.82

OPTOTUNE LIQUID LENS SYSTEM DIAGRAM

Zoom 6000 with Optotune and Navitar Objectives - Additional Working Distances

Lens Attachment	Optotune Power (Diopters)	Working Distance (mm)	Magnification		Object NA		Resolve Limit (µm)		Matching Pixel Size	
			Low Mag	High Mag	Low Mag	High Mag	Low Mag	High Mag	Low Mag	High Mag
4X 1-55075	-2	25	1.24	8.07	0.043	0.126	8.29	2.95	5.15	11.91
	-1	22	1.31	8.48	0.046	0.135	7.81	2.56	5.10	10.87
	0	20	1.37	8.86	0.049	0.145	7.45	2.40	5.10	10.64
	1	17	1.43	9.22	0.053	0.155	7.27	2.52	5.21	11.63
	2	15	1.50	9.58	0.056	0.166	7.19	3.26	5.38	15.63
	3	13	1.56	9.96	0.060	0.177	7.05	3.24	5.49	16.13
6X 1-55401	-2	27	2.11	13.88	0.072	0.213	4.88	1.85	5.15	12.82
	-1	26	2.08	13.53	0.213	0.214	4.91	1.64	5.10	11.11
	0	25	2.05	13.17	0.214	0.217	4.99	1.62	5.10	10.64
	1	24	2.01	12.82	0.217	0.219	5.28	1.90	5.32	12.19
	2	23	1.98	12.50	0.219	0.221	5.61	2.35	5.55	14.71
	3	21	1.95	12.22	0.224	0.224	6.04	2.73	5.88	16.67

Adapter Tube Required
(1-6015 or 1-6218 suggested)

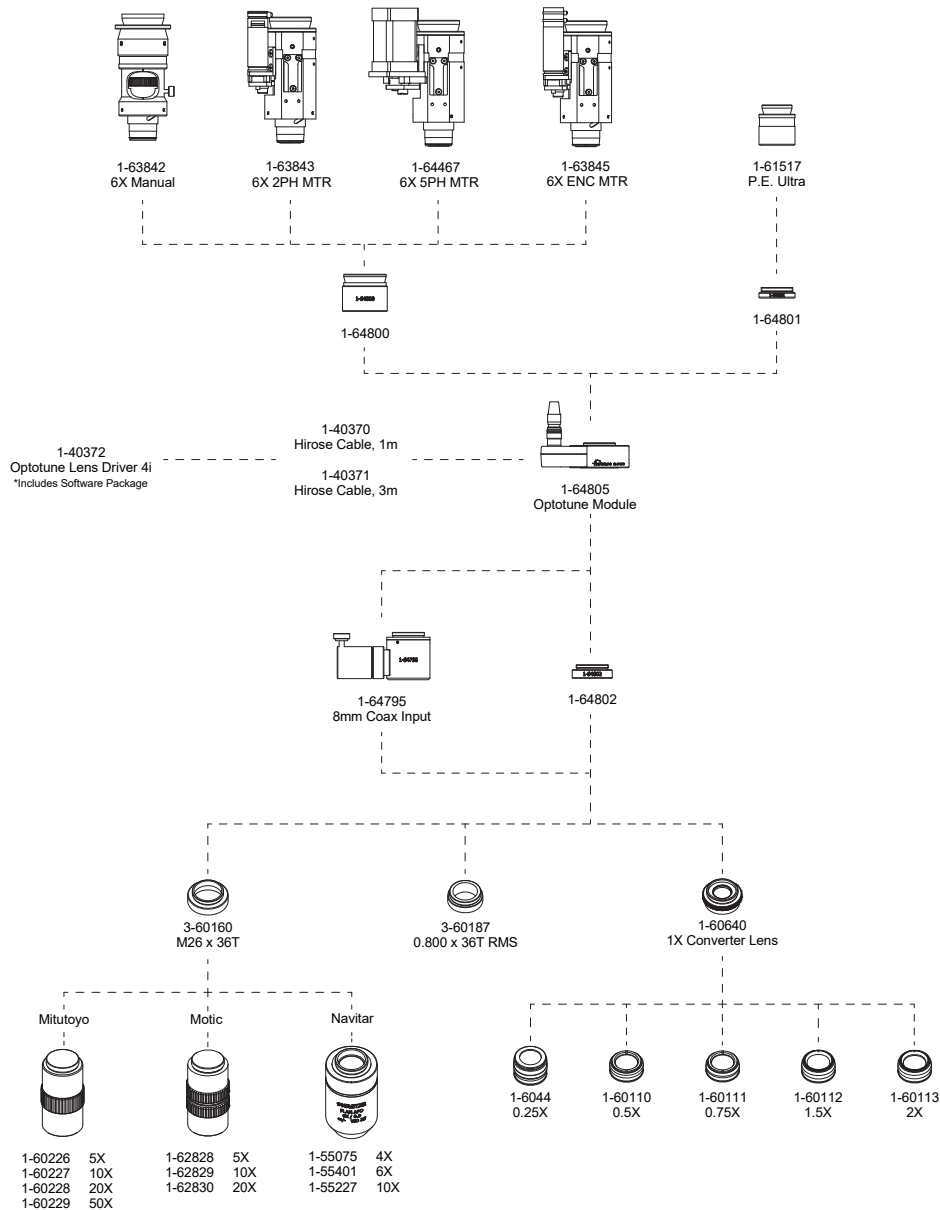

12X ZOOM LENS SYSTEM

Navitar's Highest Combination of Zoom Range and Resolution

For high magnification applications requiring the optimal balance between optical performance, large zoom range and price, the 12X is an ideal choice. The 12X Zoom incorporates all the mechanical flexibility of the Zoom 6000 with extended zoom range, higher NA and unbeatable accuracy and repeatability for the most demanding applications. This outstanding combination of zoom range, coupled with large field coverage, means that you will now be able to view a wider range of parts with a single video inspection system and eliminate the need for bulky microscopes.

- Incredible 12X (0.58-7X) magnification for inspection of a wider range of parts
- Increased resolution with 0.005 - 0.550 NA
- Variable working distance from 13 to 341 mm
- Field of view from 0.006 mm to 85.71 mm with attachments
- Unmatched edge flatness and clarity
- Works with 1/4", 1/3", 1/2" and 2/3" format cameras
- The 12X Zoom System utilizes existing Zoom 6000 adapter tubes
- Body tubes with detents, apertures or motorized are available



12X Zoom Field of View Matrix (in mm)

Lens Attachment	W.D. (mm)	Camera Formats/Parameters	0.5X Adapter Low-High	0.67X Adapter Low-High	1X Adapter Low-High	1.33X Adapter Low-High	2X Adapter Low-High	3.3X Adapter Low-High	Resolve Limit (µm) Low-High	Depth of Field (mm) Low-High
0.25X (2)0.005 - 0.025 NA 1-50011	341	Mag.	0.07X - 0.87X	0.10X - 1.20X	0.15X - 1.75X	0.19X - 2.33X	0.29X - 3.50X	0.48X - 5.78X	66.66 - 13.34	20.00 - 0.80
		1/4" Sensor	57.14 - 4.59	41.16 - 3.40	27.60 - 2.28	21.05 - 1.72	13.90 - 1.14	8.36 - 0.69	66.66 - 13.34	20.00 - 0.80
		1/3" Sensor	85.71 - 6.89	61.73 - 5.10	41.38 - 3.42	31.57 - 2.57	20.69 - 1.71	12.54 - 1.04	66.66 - 13.34	20.00 - 0.80
		1/2" Sensor	—	82.32 - 6.80	55.16 - 4.56	42.10 - 3.43	27.58 - 2.28	16.72 - 1.38	66.66 - 13.34	20.00 - 0.80
		2/3" Sensor	—	(1) 72.00 - 9.35	75.88 - 6.28	57.89 - 4.72	37.94 - 3.14	22.99 - 1.90	66.66 - 13.34	20.00 - 0.80
0.5X 0.009 - 0.051 NA 1-50012	165	Mag.	0.14X - 1.75X	0.20X - 2.40X	0.29X - 3.50X	0.39X - 4.66X	0.58X - 7.00X	0.96X - 11.55X	37.04 - 6.66	6.17 - 0.19
		1/4" Sensor	28.57 - 2.28	20.58 - 1.70	13.79 - 1.14	10.25 - 0.86	6.90 - 0.76	4.18 - 0.35	37.04 - 6.66	6.17 - 0.19
		1/3" Sensor	42.85 - 3.42	30.87 - 2.55	20.69 - 1.71	15.38 - 1.29	10.34 - 0.86	6.27 - 0.52	37.04 - 6.66	6.17 - 0.19
		1/2" Sensor	—	41.16 - 3.40	27.58 - 2.28	20.51 - 1.72	13.79 - 1.14	8.36 - 0.69	37.04 - 6.66	6.17 - 0.19
		2/3" Sensor	—	(1) 36.00 - 4.68	37.94 - 3.14	28.20 - 2.36	18.97 - 1.57	11.50 - 0.95	37.04 - 6.66	6.17 - 0.19
0.75X 0.014 - 0.076 NA 1-50013	108	Mag.	0.22X - 2.62X	0.29X - 3.50X	0.44X - 5.30X	0.58X - 6.98X	0.87X - 10.50X	1.44X - 17.33X	23.80 - 4.44	2.55 - 0.09
		1/4" Sensor	18.18 - 1.52	13.72 - 1.14	9.19 - 0.76	6.89 - 0.57	4.60 - 0.38	2.78 - 0.23	23.80 - 4.44	2.55 - 0.09
		1/3" Sensor	27.27 - 2.29	20.58 - 1.70	13.79 - 1.14	10.34 - 0.85	6.89 - 0.57	4.18 - 0.35	23.80 - 4.44	2.55 - 0.09
		1/2" Sensor	—	27.44 - 2.27	18.34 - 1.52	13.79 - 1.14	9.19 - 0.76	5.56 - 0.46	23.80 - 4.44	2.55 - 0.09
		2/3" Sensor	—	(1) 24.30 - 3.12	25.30 - 2.09	18.96 - 1.57	12.64 - 1.05	7.67 - 0.63	23.80 - 4.44	2.55 - 0.09
None 0.019 - 0.101 NA	86	Mag.	0.29X - 3.49X	0.39X - 4.70X	0.58X - 7.00X	0.77X - 9.31X	1.16X - 14.00X	1.91X - 23.10X	18.52 - 3.34	1.39 - 0.05
		1/4" Sensor	13.79 - 1.14	10.29 - 0.85	6.90 - 0.57	5.19 - 0.43	3.45 - 0.29	2.09 - 0.17	18.52 - 3.34	1.39 - 0.05
		1/3" Sensor	20.69 - 1.72	15.44 - 1.28	10.34 - 0.86	7.79 - 0.64	5.18 - 0.43	3.13 - 0.26	18.52 - 3.34	1.39 - 0.05
		1/2" Sensor	—	20.58 - 1.70	13.79 - 1.14	10.39 - 0.86	6.90 - 0.57	4.18 - 0.35	18.52 - 3.34	1.39 - 0.05
		2/3" Sensor	—	(1) 18.20 - 2.34	18.97 - 1.57	14.28 - 1.18	9.49 - 0.78	5.75 - 0.48	18.52 - 3.34	1.39 - 0.05
1.5X 0.028 - 0.151 NA 1-50014	50	Mag.	0.43X - 5.23X	0.58X - 7.00X	0.87X - 10.50X	1.16X - 14.0X	1.74X - 21.00X	2.87X - 34.65X	12.34 - 2.24	0.64 - 0.02
		1/4" Sensor	9.30 - 0.76	6.86 - 0.57	4.60 - 0.38	3.44 - 0.28	2.30 - 0.19	1.39 - 0.12	12.34 - 2.24	0.64 - 0.02
		1/3" Sensor	13.95 - 1.14	10.29 - 0.85	6.89 - 0.57	5.17 - 0.44	3.45 - 0.29	2.09 - 0.17	12.34 - 2.24	0.64 - 0.02
		1/2" Sensor	—	13.72 - 1.13	9.19 - 0.76	6.89 - 0.57	4.60 - 0.38	2.78 - 0.23	12.34 - 2.24	0.64 - 0.02
		2/3" Sensor	—	(1) 12.20 - 1.55	12.64 - 1.05	9.48 - 0.78	6.33 - 0.52	3.83 - 0.323	12.34 - 2.24	0.64 - 0.02
2.0X 0.038 - 0.202 NA 1-50015	37	Mag.	0.58X - 6.98X	0.78X - 9.40X	1.16X - 14.00X	1.54X - 18.6X	2.32X - 28.00X	3.83X - 46.20X	9.00 - 1.66	0.35 - 0.01
		1/4" Sensor	6.89 - 0.57	5.14 - 0.43	3.45 - 0.29	2.59 - 0.21	1.73 - 0.15	1.05 - 0.09	9.00 - 1.66	0.35 - 0.01
		1/3" Sensor	10.34 - 0.85	7.72 - 0.64	5.18 - 0.43	3.89 - 0.32	2.59 - 0.22	1.57 - 0.13	9.00 - 1.66	0.35 - 0.01
		1/2" Sensor	—	10.29 - 0.85	6.90 - 0.57	5.19 - 0.43	3.45 - 0.29	2.09 - 0.17	9.00 - 1.66	0.35 - 0.01
		2/3" Sensor	—	(1) 9.10 - 1.17	9.49 - 0.78	7.14 - 0.59	4.75 - 0.40	2.88 - 0.24	9.00 - 1.66	0.35 - 0.01

22 (1) Vignetting occurs at zoom settings less than 0.9X.
 (2) NA varies depending on zoom setting. The above fields of view are measured diagonally in millimeters (Horizontal = Diagonal x 0.8 and Vertical = Diagonal x 0.6).

12X Zoom Performance Specifications

12X Zoom Combinations Lens Attach. + Prime Lens + Adapter	Working Distance (mm)	System Mag.	NA Objective	Resolve Limit (µm)	Matching Pixel Size (µm)	Depth of Field (mm)
		Low-High	Low-High	Low-High	Low-High	Low-High
0.25x + 12X Zoom + 0.5x	341	0.07 - 0.87	0.005 - 0.025	66.66 - 13.34	2.33 - 5.8	20.00 - 0.80
0.25x + 12X Zoom + 0.67x	341	0.10 - 1.17	0.005 - 0.025	66.66 - 13.34	3.33 - 7.80	20.00 - 0.80
0.25x + 12X Zoom + 1.0x	341	0.15 - 1.75	0.005 - 0.025	66.66 - 13.34	5.00 - 11.67	20.00 - 0.80
0.25x + 12X Zoom + 1.33x	341	0.19 - 2.33	0.005 - 0.025	66.66 - 13.34	6.33 - 15.54	20.00 - 0.80
0.25x + 12X Zoom + 2.0x	341	0.29 - 3.50	0.005 - 0.025	66.66 - 13.34	9.67 - 23.34	20.00 - 0.80
0.25x + 12X Zoom + 3.3x	341	0.48 - 5.78	0.005 - 0.025	66.66 - 13.34	16.59 - 40.53	20.00 - 0.80
0.5x + 12X Zoom + 0.5x	165	0.14 - 1.75	0.009 - 0.051	37.04 - 6.66	2.59 - 5.82	6.17 - 0.19
0.5x + 12X Zoom + 0.67x	165	0.19 - 2.35	0.009 - 0.051	37.04 - 6.66	3.60 - 7.68	6.17 - 0.19
0.5x + 12X Zoom + 1.0x	165	0.29 - 3.50	0.009 - 0.051	37.04 - 6.66	5.38 - 11.45	6.17 - 0.19
0.5x + 12X Zoom + 1.33x	165	0.39 - 4.66	0.009 - 0.051	37.04 - 6.66	7.22 - 15.51	6.17 - 0.19
0.5x + 12X Zoom + 2.0x	165	0.58 - 7.00	0.009 - 0.051	37.04 - 6.66	10.74 - 22.89	6.17 - 0.19
0.5x + 12X Zoom + 3.3x	165	0.96 - 11.55	0.009 - 0.051	37.04 - 6.66	16.64 - 50.60	6.17 - 0.19
0.75x + 12X Zoom + 0.5x	108	0.22 - 2.62	0.014 - 0.076	23.80 - 4.44	2.61 - 5.81	2.55 - 0.09
0.75x + 12X Zoom + 0.67x	108	0.29 - 3.52	0.014 - 0.076	23.80 - 4.44	3.45 - 7.73	2.55 - 0.09
0.75x + 12X Zoom + 1.0x	108	0.44 - 5.25	0.014 - 0.076	23.80 - 4.44	5.24 - 11.52	2.55 - 0.09
0.75x + 12X Zoom + 1.33x	108	0.58 - 6.98	0.014 - 0.076	23.80 - 4.44	6.90 - 15.49	2.55 - 0.09
0.75x + 12X Zoom + 2.0x	108	0.87 - 10.50	0.014 - 0.076	23.80 - 4.44	10.35 - 23.05	2.55 - 0.09
0.75x + 12X Zoom + 3.3x	108	1.44 - 17.33	0.014 - 0.076	23.80 - 4.44	16.62 - 46.34	2.55 - 0.09
None + 12X Zoom + 0.5x	86	0.29 - 3.49	0.019 - 0.101	18.52 - 3.34	2.68 - 5.82	1.39 - 0.05
None + 12X Zoom + 0.67x	86	0.39 - 4.69	0.019 - 0.101	18.52 - 3.34	3.42 - 7.74	1.39 - 0.05
None + 12X Zoom + 1.0x	86	0.58 - 7.00	0.019 - 0.101	18.52 - 3.34	5.09 - 11.55	1.39 - 0.05
None + 12X Zoom + 1.33x	86	0.77 - 9.31	0.019 - 0.101	18.52 - 3.34	7.13 - 15.54	1.39 - 0.05
None + 12X Zoom + 2.0x	86	1.16 - 14.00	0.019 - 0.101	18.52 - 3.34	10.17 - 23.10	1.39 - 0.05
None + 12X Zoom + 3.3x	86	1.91 - 23.10	0.019 - 0.101	18.52 - 3.34	16.60 - 40.54	1.39 - 0.05
1.5x + 12X Zoom + 0.5x	50	0.43 - 5.23	0.028 - 0.151	12.34 - 2.24	2.65 - 5.85	0.64 - 0.02
1.5x + 12X Zoom + 0.67x	50	0.58 - 7.04	0.028 - 0.151	12.34 - 2.24	3.45 - 7.78	0.64 - 0.02
1.5x + 12X Zoom + 1.0x	50	0.87 - 10.50	0.028 - 0.151	12.34 - 2.24	5.18 - 11.60	0.64 - 0.02
1.5x + 12X Zoom + 1.33x	50	1.16 - 14.00	0.028 - 0.151	12.34 - 2.24	7.15 - 15.68	0.64 - 0.02
1.5x + 12X Zoom + 2.0x	50	1.74 - 21.00	0.028 - 0.151	12.34 - 2.24	10.74 - 23.34	0.64 - 0.02
1.5x + 12X Zoom + 3.3x	50	2.87 - 34.65	0.028 - 0.151	12.34 - 2.24	16.62 - 40.77	0.64 - 0.02
2.0x + 12X Zoom + 0.5x	37	0.58 - 6.98	0.038 - 0.202	9.00 - 1.66	2.61 - 5.79	0.35 - 0.01
2.0x + 12X Zoom + 0.67x	37	0.78 - 9.38	0.038 - 0.202	9.00 - 1.66	3.42 - 7.79	0.35 - 0.01
2.0x + 12X Zoom + 1.0x	37	1.16 - 14.00	0.038 - 0.202	9.00 - 1.66	5.09 - 11.62	0.35 - 0.01
2.0x + 12X Zoom + 1.33x	37	1.54 - 18.60	0.038 - 0.202	9.00 - 1.66	6.93 - 15.43	0.35 - 0.01
2.0x + 12X Zoom + 2.0x	37	2.32 - 28.00	0.038 - 0.202	9.00 - 1.66	10.17 - 23.24	0.35 - 0.01
2.0x + 12X Zoom + 3.3x	37	3.83 - 46.20	0.038 - 0.202	9.00 - 1.66	16.56 - 36.04	0.35 - 0.01

Assumptions:

1. Minimum resolvable feature size is half of the threshold line pair limit. Calculation = $1/(3000 \times \text{Lens NA})$
2. Matching pixel size is that which will permit the minimum feature size to overlap two pixels. Calculation = $1/2(\text{Feature Size} \times \text{System Magnification})$
3. If the matching pixel size is greater than the camera pixel size, the system is "lens limited.", if less than the camera pixel size, the system is "camera limited."

Unmatched Optical Quality for High Magnification Applications

Navitar's 12X UltraZoom incorporates infinity corrected objectives in an advanced design that offers long working distances and outstanding edge flatness and clarity. The UltraZoom is also available with fine focus or with fine focus and coaxial illumination.

12X UltraZoom Field of View Matrix for 1-50502, 1-50503 and 1-50504 (mm)

Objective Lens Long W.D.	W.D. (mm)	Camera Formats/ Parameters	1X Adapter Low - High	1.33X Adapter Low - High	2X Adapter Low - High	3.3X Adapter Low - High
4X 0.20 NA* 1-55341	20	Mag.	(1) 2.90X - 13.35X	(2) 2.61X - 17.75X	2.19X - 26.69X	3.61X - 44.04X
		1/4" Sensor	1.38 - 0.30	1.53 - 0.23	1.83 - 0.15	1.11 - 0.09
		1/3" Sensor	2.07 - 0.45	2.30 - 0.34	2.74 - 0.22	1.66 - 0.14
		1/2" Sensor	2.76 - 0.60	3.06 - 0.45	3.65 - 0.30	2.21 - 0.18
		2/3" Sensor	3.79 - 0.82	4.21 - 0.62	5.02 - 0.41	3.04 - 0.25
5X 0.14 NA* 1-60226	34	Mag.	(1) 3.57X - 16.66X	(2) 3.26X - 22.16X	2.77X - 33.31X	4.52X - 55.05X
		1/4" Sensor	1.12 - 0.24	1.22 - 0.18	1.44 - 0.12	0.89 - 0.07
		1/3" Sensor	1.68 - 0.36	1.84 - 0.27	2.17 - 0.18	1.33 - 0.11
		1/2" Sensor	2.24 - 0.48	2.45 - 0.36	2.89 - 0.24	1.77 - 0.15
		2/3" Sensor	—	2.45 - 0.49	3.97 - 0.33	2.44 - 0.20
10X 0.28 NA* 1-60227	33	Mag.	(1) 7.14X - 33.31X	(2) 6.50X - 44.30X	5.54X - 66.63X	9.03X - 110.10X
		1/4" Sensor	0.56 - 0.12	0.61 - 0.09	0.72 - 0.06	0.44 - 0.04
		1/3" Sensor	0.84 - 0.18	0.92 - 0.13	1.08 - 0.09	0.66 - 0.05
		1/2" Sensor	1.12 - 0.24	1.23 - 0.18	1.44 - 0.12	0.89 - 0.07
		2/3" Sensor	—	1.23 - 0.25	1.99 - 0.17	1.22 - 0.10
20X 0.42 NA* 1-60228	20	Mag.	(1) 14.28X - 64.63X	(2) 13.10X - 85.96X	11.08X - 133.25X	18.07X - 220.21X
		1/4" Sensor	0.28 - 0.06	0.30 - 0.04	0.36 - 0.03	0.22 - 0.02
		1/3" Sensor	0.42 - 0.09	0.46 - 0.07	0.54 - 0.04	0.33 - 0.03
		1/2" Sensor	0.56 - 0.12	0.61 - 0.09	0.72 - 0.06	0.44 - 0.04
		2/3" Sensor	—	0.61 - 0.13	0.99 - 0.08	0.61 - 0.05
50X 0.55 NA* 1-60229	13	Mag.	(1) 35.69X - 166.57X	(2) 40.00X - 221.54X	27.50X - 333.13X	45.17X - 550.52X
		1/4" Sensor	0.11 - 0.02	0.10 - 0.02	0.14 - 0.01	0.09 - 0.007
		1/3" Sensor	0.17 - 0.04	0.15 - 0.05	0.22 - 0.02	0.13 - 0.010
		1/2" Sensor	0.22 - 0.05	0.20 - 0.04	(2) 0.17 - 0.03	0.18 - 0.010
		2/3" Sensor	—	0.20 - 0.05	0.40 - 0.03	0.24 - 0.020

NOTE: This system is not recommended for use with a 2/3" Sensor.

(1) Zoom setting at 1.5X.

(2) Zoom setting at 1.0X.

*NA at high mag. NA varies with zoom setting.



12X Zoom with Co-axial Illumination

Navitar's 12X Zoom with Internal Co-axial Illumination (1-50487) is ideal for applications involving highly reflective surfaces, such as wafers, polished samples, and fluids. Designed to provide even illumination for higher magnification applications, it provides extremely detailed resolution under incident lighting, particularly when a high resolution camera is used. Various illumination sources can be used.

Field of View Matrix for 12X Zoom with Co-axial Illumination - 1-50487 (mm)

Lens Attachment	W. D. (mm)	Camera Formats/ Parameters	.67X Adapter Low - High	1X Adapter Low - High	1.33X Adapter Low - High	2X Adapter Low - High	3.3X Adapter Low - High
None 0.019 - 0.101 NA (2)	86	Mag.	0.39X - 4.70X	0.58X - 7.00X	0.77X - 9.31X	1.16X - 14.00X	1.39X - 0.05X
		1/4" Sensor	10.29 - 0.85	6.90 - 0.57	5.19 - 0.43	3.45 - 0.29	2.09 - 0.17
		1/3" Sensor	15.44 - 1.28	10.34 - 0.86	7.80 - 0.64	5.18 - 0.43	3.13 - 0.26
		1/2" Sensor	20.58 - 1.70	13.79 - 1.14	10.39 - 0.86	6.90 - 0.57	4.18 - 0.35
		2/3" Sensor	(1) 18.20 - 2.34	18.97 - 1.57	14.28 - 1.18	9.49 - 0.78	5.75 - 0.48
1.5X 0.028 - 0.151 NA (2) 1-50014	50	Mag.	0.58X - 7.00X	0.87 - 10.50X	1.16X - 14.00X	1.74X - 21.00X	2.87X - 34.65X
		1/4" Sensor	6.86 - 0.57	4.60 - 0.38	3.45 - 0.29	2.30 - 0.19	1.39 - 0.12
		1/3" Sensor	10.29 - 0.85	6.89 - 0.57	5.17 - 0.43	3.45 - 0.29	2.09 - 0.17
		1/2" Sensor	13.72 - 1.13	9.19 - 0.76	6.89 - 0.57	4.60 - 0.38	2.78 - 0.23
		2/3" Sensor	(1) 12.20 - 1.55	12.64 - 1.05	9.48 - 0.79	6.33 - 0.52	3.83 - 0.32
2.0X 0.038 - 0.202 NA (2) 1-50015	37	Mag.	0.78X - 9.40X	1.16X - 14.00X	1.54X - 18.6X	2.32X - 28.00X	3.83X - 46.20X
		1/4" Sensor	5.14 - 0.43	3.45 - 0.29	2.59 - 0.22	1.73 - 0.15	1.05 - 0.09
		1/3" Sensor	7.72 - 0.64	5.18 - 0.43	3.89 - 0.32	2.59 - 0.22	1.57 - 0.13
		1/2" Sensor	10.29 - 0.85	6.90 - 0.57	5.19 - 0.43	3.45 - 0.29	2.09 - 0.17
		2/3" Sensor	(1) 9.10 - 1.17	9.49 - 0.78	7.14 - 0.59	4.75 - 0.40	2.88 - 0.24

NOTE:

The internal coax will illuminate a circular area of about 14 mm in diameter. Any field of view larger than 14 mm will have darkened corners. Low power lens attachments can be used but produce increasing vignetting.

(1) Zoom Setting at 1.0X.

(2) NA varies depending on zoom setting

Get Precise Measurement with the 12X Telecentric Zoom

Navitar offers a 12X Telecentric zoom system that allows users to reach a true telecentric condition to within 0.4 degrees, while maintaining constant perspective and magnification. Ideal for a wide range of applications, including precise dimensional measurement of objects or pattern recognition.

There are four telecentric adapters available for use with the 12X Zoom lens: straight (no coax), straight with coax, right-angle adapter without coax and right-angle folded with coax. When combined with the 1-50993 12X zoom the telecentric attachments will have a nominal working distance of 173mm +/- 2mm. The working distance can be modified by the factory from 165 to 186mm. Magnifications range from 0.16X to 1.94X with the 1X adapter, and 0.32X to 3.88X with the 2X adapter. Maximum field of view is 50 mm. An upper 2X F-mount adapter may be used to couple an F-Mount camera.

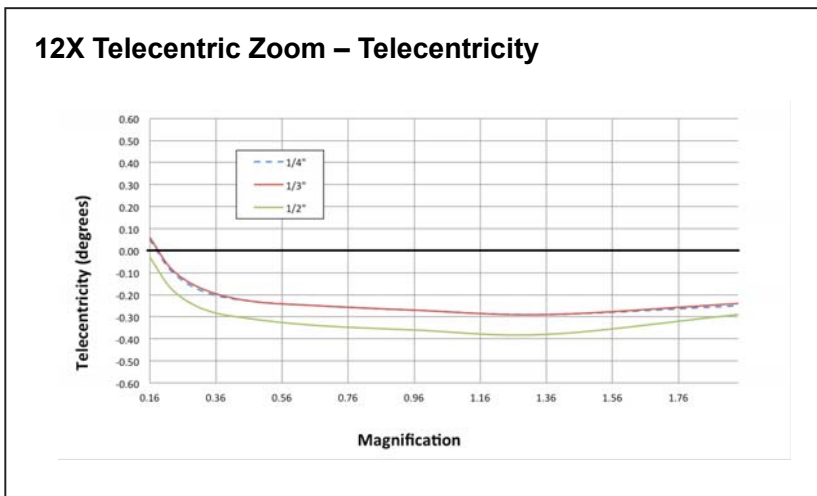
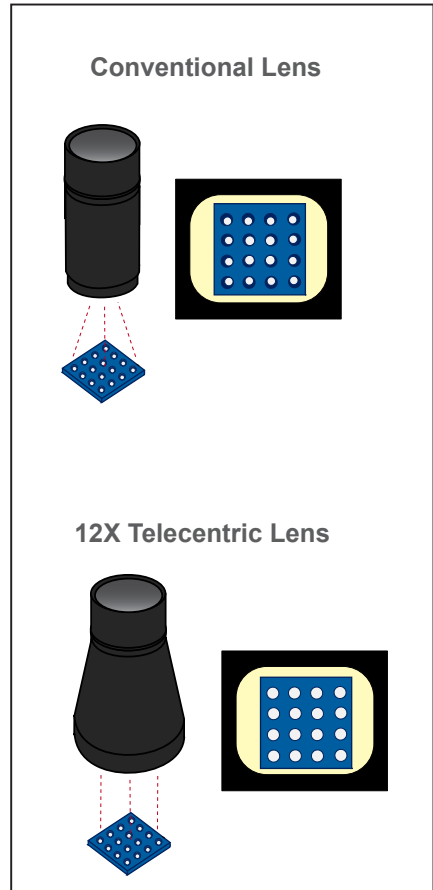

12X Telecentric Zoom Lens Specifications

Mag.	Telecentricity (degrees)			Object NA	Image NA	Object Depth of Focus (mm)	Telecentric Error (mm)			FOV Size (mm)			Approx. MTF (lp/mm)	Resolvable Features (µm)
	1/4"	1/3"	1/2"				1/4"	1/3"	1/2"	1/4"	1/3"	1/2"		
0.16X	0.05	0.06	-0.03	0.005	0.032	19.4	0.018	0.020	-0.009	25.0	37.3	49.7	15	66
0.23X	-0.10	-0.09	-0.18	0.007	0.031	9.7	-0.017	-0.016	-0.030	17.4	26.1	34.8	22	46
0.33X	-0.19	-0.18	-0.27	0.010	0.030	5.2	-0.016	-0.016	-0.024	12.1	18.2	24.3	30	34
0.47X	-0.23	-0.23	-0.31	0.013	0.028	3.0	-0.012	-0.012	-0.016	8.5	12.8	17.0	39	26
0.67X	-0.25	-0.25	-0.34	0.016	0.024	1.9	-0.008	-0.008	-0.011	5.9	8.9	11.9	49	21
0.96X	-0.27	-0.27	-0.36	0.020	0.021	1.3	-0.006	-0.006	-0.008	4.2	6.3	8.4	59	17
1.36X	-0.29	-0.29	-0.38	0.024	0.017	0.9	-0.004	-0.005	-0.006	2.9	4.4	5.9	71	14
1.94X	-0.25	-0.24	-0.29	0.028	0.015	0.6	-0.003	-0.003	-0.003	2.1	3.1	4.1	84	12

NIR Lens System for Zoom 6000, 12X Zoom and Precise Eye

Navitar's NIR Zoom lens system offers high resolution and unparalleled sensitivity for capturing microscopic images. We have specially coated the glass on our high magnification systems to be optimized for imaging in the 700-1550nm wavelength range.

Body tubes with detents and apertures or motorized systems are available.

Note: Since NIR lenses are not operating within the visible spectrum, the resulting image is slightly different than when using a standard zoom system. The standard lens resolution limits of an NIR lens are based on an assumed average wavelength of 0.5 microns and is inversely proportional to wavelength (maximum MTF = 3000xNA in the visible wavelength). Therefore, substituting a wavelength of 1.5 microns will reduce the maximum resolution by a factor of 3. In practice, this means a slight reduction of contrast at the higher wavelengths.

(When changing wavelengths in the NIR region minor refocus might be required.)

Applications Where Navitar NIR Optics are Useful

- Wafer characterization
- Laser beam profiling
- Optical component measurement and analysis
- Fiber alignment and inspection
- Assembly and monitoring
- Hyperspectral microscopy

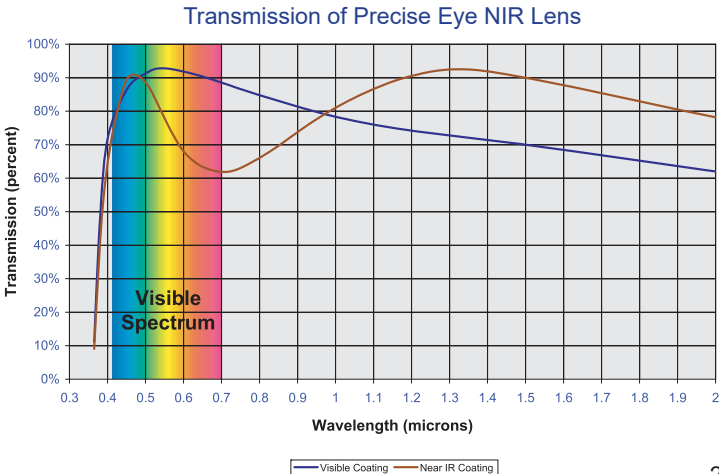
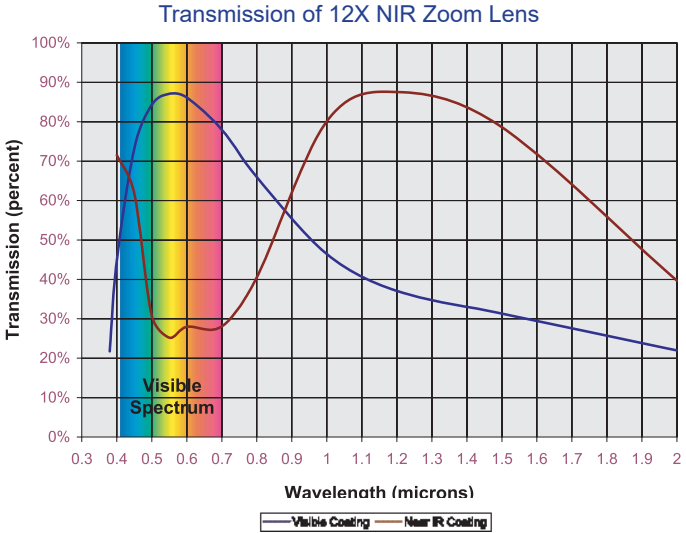
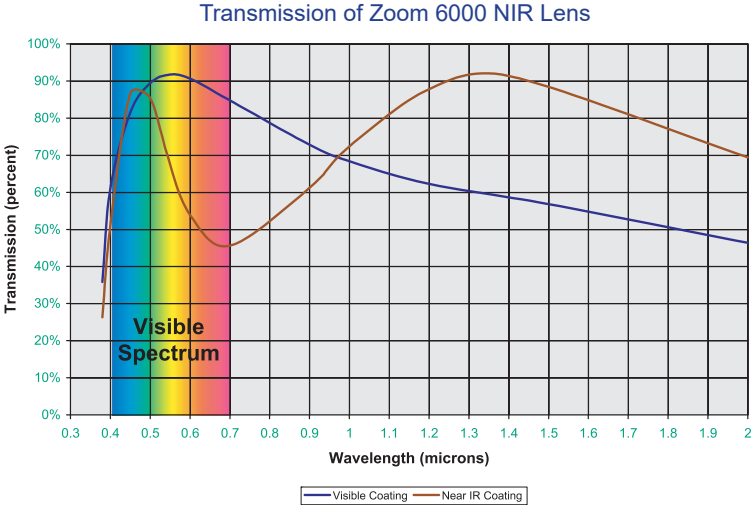

12X ZOOM SYSTEM DIAGRAM

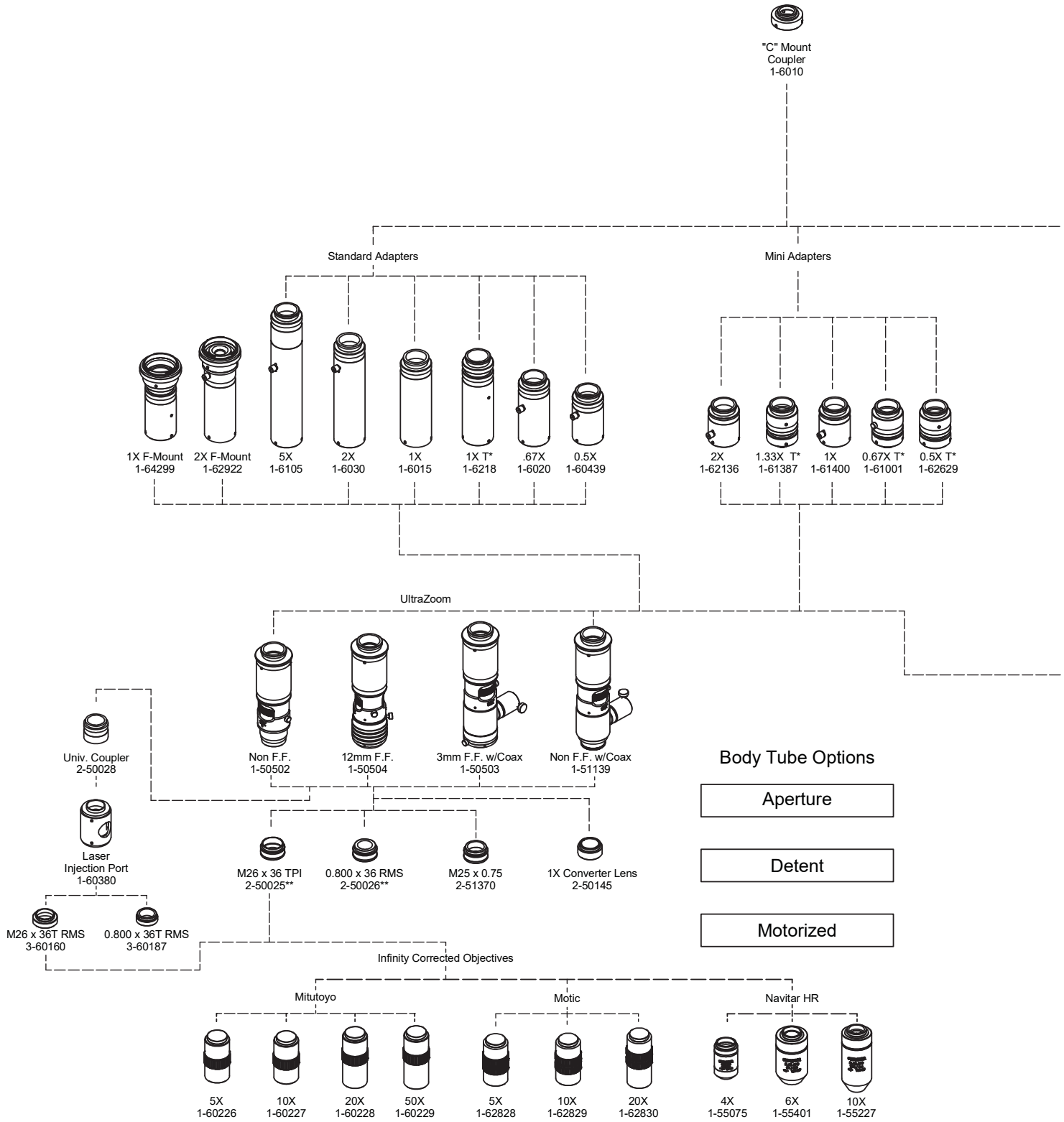

*T = Tele
** Included with UltraZoom

12X ZOOM SYSTEM DIAGRAM

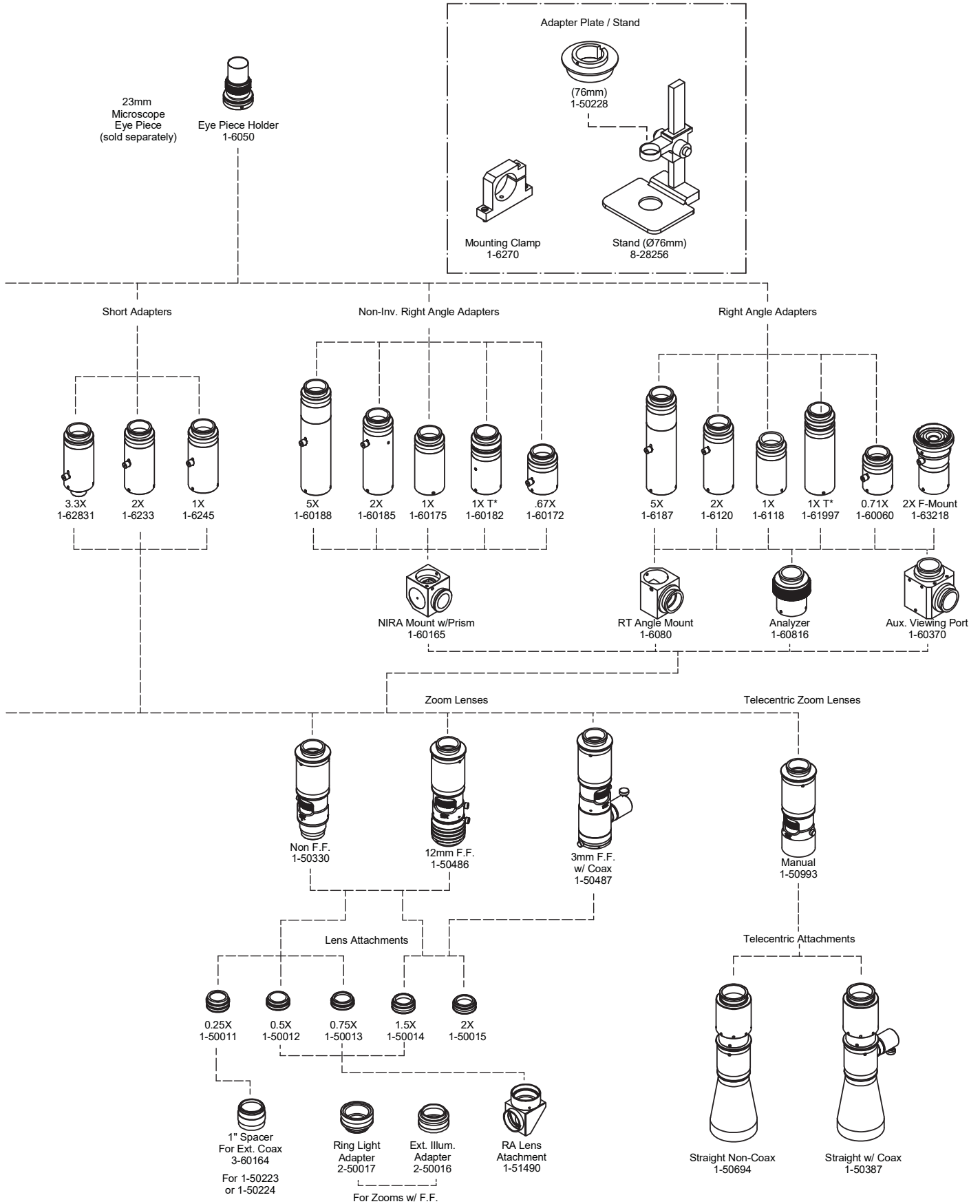

Differential Interference Contrast (DIC) Modules

Available for Zoom 6000 and 12X Zoom Systems

Two Differential Interference Contrast (DIC) modules are available from Navitar:

- DIC Assembly Nikon-High Resolution module (1-63726)
- Original DIC Assembly module (1-63102)

Both modules can be used on any ultra coax version (zoom or non-zoom) of the Zoom 6000 and 12X Zoom.

DIC, when used with brightfield illumination, can often be interpreted as a true three-dimensional representation of the surface geometry. It provides a clear distinction between raised and lowered regions in the specimen being viewed.

Using the DIC module in reflected light situations

Two polarizers, one in the illumination axis and one in the viewing axis, are crossed at 90 degrees such that when looking at a perfectly mirrored surface all light is extinguished by the second polarizer.

A prism, made from two pieces of quartz, is then placed between the illuminator beamsplitter and the objective. Due to the optical properties of the quartz, the polarized beam is split into two. The two beams, separated by a minuscule amount, are polarized at 90 degrees to each other and one beam is shifted in relation to the other - a phase shift.

If the subject being viewed exhibits properties that change the length of the optical path of either beam (such as surface profiles, optical densities, etc.), both beams will experience further phase shifts.

With transverse movement of the prism the phase shifting performance of the prism may be accentuated and the final image is modified. By adding a polarization modifier, such as a 1/4 wave plate, after the illumination polarizer, the final effects are modified further.

The DIC module works with object side NAs ranging from 0.05 to 0.50, with optimum performance in the range from 0.15 to 0.4. Lens attachments, operating in the above range will serve for macro applications. Any infinity corrected objectives designed for incident light will suffice for micro applications. Operating parameters, such as magnification and FOV, will be the same as Navitar's existing tables for the zoom system being used.

3D topography of a flat panel display circuit highlighted by employing differential interference contrast (DIC) and the Zoom 6000.

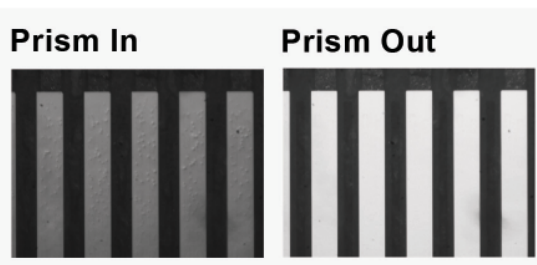
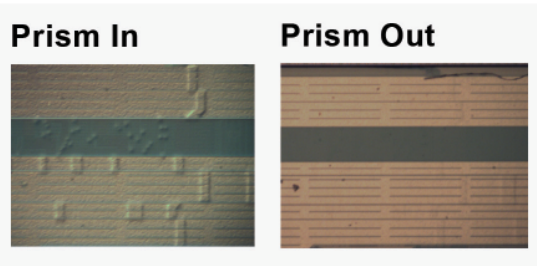

DIC MODULE SYSTEM DIAGRAM

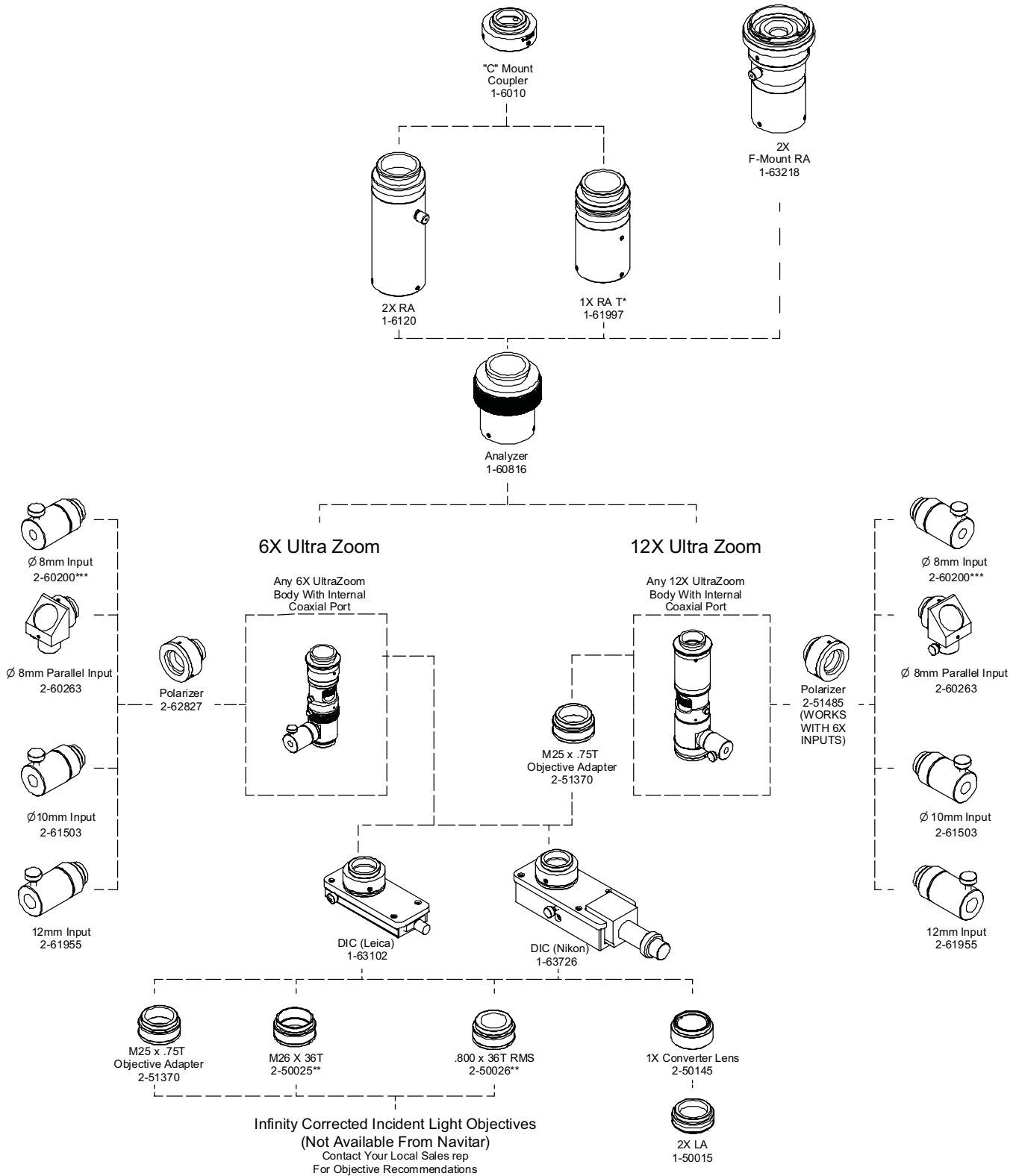

*T = Tele

** Included With 12X UltraZooms

*** Included With Manual 6000 UltraZooms

ZOOM 6000 & 12X ZOOM ACCESSORIES

Right Angle Accessories

The RA mount (1-6080) introduces a 90° bend in the optical axis, shortening the overall length of the system. The resulting image will be mirrored, thus erect and read backwards from right to left when viewed with a camera.

Non-Inverting Right Angle Accessories

The Non-Inverting RA mount (1-60165) introduces a 90° bend in the optical axis. The use of a penta prism results in an image that is erect and reads left to right.

Object Side Inverting & Non-Inverting Right Angle Attachments

Navitar offers a series of attachments that are fitted to the object side of our Zoom 6000 and 12X systems. See system diagrams.

Adapter Plates

Navitar offers a variety of different microscope converter plates so you can use your zoom system with Nikon, Olympus, Meiji, and Leica focus mounts.

Polarizer/Analyzer

When used in conjunction with a polarized light source, an analyzer (1-60816) allows for cross polarization of the light in the imaging system. This reduces reflections that can deteriorate the image quality. The analyzer must be used in conjunction with the right angle adapters.

If you choose to add a polarization option to your lens system, it requires an illumination polarizer (2-62827), an analyzer above the zoom, a quarter wave plate (optional), and a shorter version of an Adapter (RA) because the analyzer shortens the optical path by 50.8 mm.

Aperture Control

Lens systems can be designed with an internal iris that can be manipulated without cutting into the field of view. The iris permits the reduction of image intensity at the image plane, which reduces "blooming" and other damaging artifacts. The iris can also be closed down to essentially "stop down" the lens to reduce the Numerical Aperture of the lens. This narrowing of the light gathering cone produces a significant increase in the depth of field.



Laser Injection Port

Navitar's Laser Injection Port (1-60380) provides a means of introducing a laser beam into the Zoom 6000 system. It is normally used between the end of the zoom lens and an infinity corrected objective so that the objective condenses the laser beam into a highly concentrated spot. A beamsplitter cube, rather than a plate, is used to minimize aberrations.

Auxiliary Viewing Port

The Auxiliary Viewing Port (1-60370) provides a second output port for an additional camera or for direct vision using an eyepiece. A 50/50 beam splitter cube is used for minimal image degradation.

Infinity Corrected Objectives

Infinity Corrected Objectives can be attached to any UltraZoom to increase the system magnification and decrease working distance.

Quarter Wave Plate

A Quarter Wave Plate (1-60981) has the unique feature of taking the polarized light and circularly polarizing the beam (sort of a spiraling effect). When this beam reflects off a specular object, the spiraling reverses, and upon re-striking the quarter wave plate, the beam is extinguished. This technique is useful in eliminating reflections from wafers and circuit boards. For use with Zoom 6000 Coaxial lens.

Zoom Xtender

The Xtender is designed to offer working distances beyond that achievable with standard attachments.

F-Mount Zoom Adapters

F-mount adapters allow use of F-mount Cameras. Not recommended for use with the 12X Zoom System with sensors over 16 mm, or the Zoom 6000 sensors over 30mm.



Zoom 6000

Basic Zoom 6000 configuration

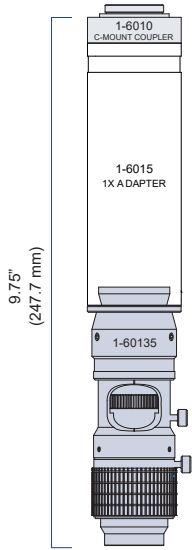

Zoom 6000 configuration with coaxial illumination

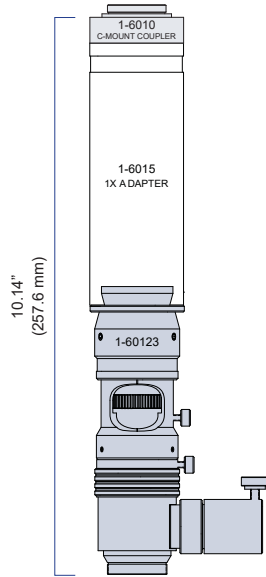

Zoom 6000 configuration with motorization

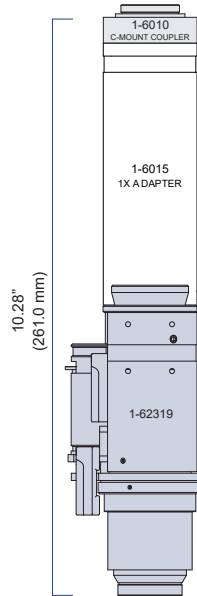

Zoom 6000 configuration with motorization and right angle adapter

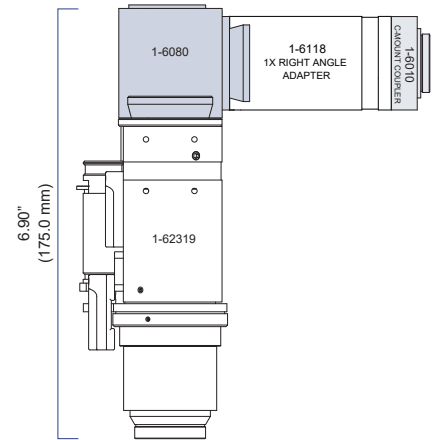

12X Zoom

Basic 12X Zoom configuration

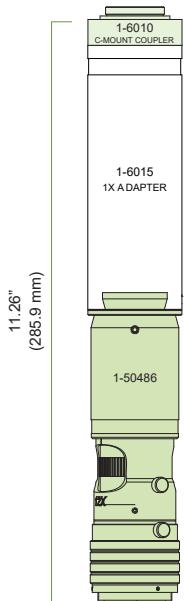

12X Zoom configuration with coaxial illumination

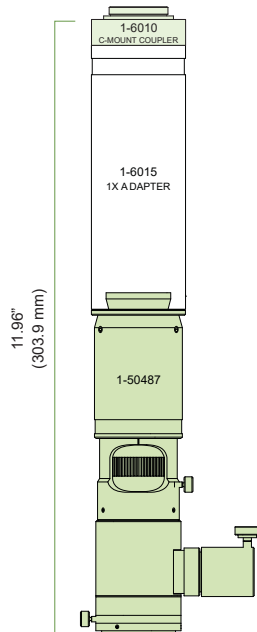

12X Zoom configuration with motorization

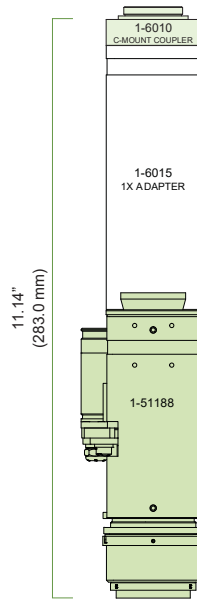

12X Zoom configuration with motorization and right angle adapter

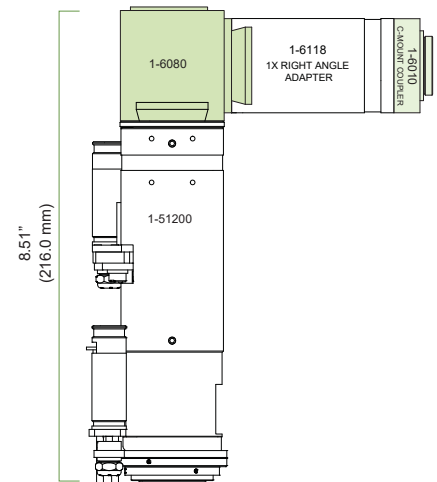

MOTORIZED SYSTEM OPTIONS

More Robust Design

Navitar's motorization design, available on the 12X and Zoom 6000 systems, integrates magnetic Hall Effect sensors with reference position location. Hall Effect sensors are solid state devices with no moving parts.

Integrated Hall Effect Solid State Sensor Technology

- Unaffected by ambient light
- Unaffected by environmental contamination
- Unaffected by line voltage

Users can choose to motorize both the zoom and focus axis, or just the zoom. Navitar offers three different motor types:

- 2-Phase Stepping Motor (Faulhaber)
- 5-Phase Stepping Motor (Oriental, Vexta)
- DC Servo with Encoder (Faulhaber)

Most motorized lenses are built to order, which may affect standard lead times.



Motorized Zoom 6000 Options

Version	Motor Type		
	2 ø Stepper	5 ø Stepper	Encoded/ Servo
12 mm Motorized Fine Focus	1-62318	1-64426	1-62310
3 mm Motorized Fine Focus w/ Coax	1-62319	1-64428	1-62311
12 mm Manual Fine Focus	1-62523	1-64430	1-62522
3 mm Manual Fine Focus w/ Coax	1-62525	1-64432	1-62524
Non Fine Focus, Non Coax	1-62605	1-64434	1-62606
Non Fine Focus w/ Coax	1-62608	1-64436	1-62609

Motorized 12X Zoom Options

Version	Motor Type		
	2 ø Stepper	5 ø Stepper	Encoded/ Servo
12 mm Motorized Fine Focus	1-51188	1-52000	1-51190
3 mm Motorized Fine Focus w/ Coax	1-51200	1-52002	1-51202
12 mm Manual Fine Focus	1-51319	1-52004	1-51337
3 mm Manual Fine Focus w/ Coax	1-51311	1-52006	1-51338
Non Fine Focus, Non Coax	1-51314	1-52008	1-51335
Non Fine Focus w/ Coax	1-51318	1-52010	1-51336

Motorized Zoom 6000 UltraZoom Options

Version	Motor Type		
	2 ø Stepper	5 ø Stepper	Encoded/ Servo
12 mm Motorized Fine Focus	1-62316	1-64439	1-62308
3 mm Motorized Fine Focus w/ Coax	1-62317	1-64441	1-62309
12 mm Manual Fine Focus	1-62517	1-64443	1-62516
3 mm Manual Fine Focus w/ Coax	1-62639	1-64445	1-62633
Non Fine Focus, Non Coax	1-62637	1-64447	1-62631
Non Fine Focus w/ Coax	1-62638	1-64449	1-62632

Motorized 12X UltraZoom Options

Version	Motor Type		
	2 ø Stepper	5 ø Stepper	Encoded/ Servo
12 mm Motorized Fine Focus	1-51192	1-52013	1-51194
3 mm Motorized Fine Focus w/ Coax	1-51196	1-52015	1-51198
12 mm Manual Fine Focus	1-51325	1-52017	1-51333
3 mm Manual Fine Focus w/ Coax	1-51326	1-52019	1-51334
Non Fine Focus, Non Coax	1-51320	1-52021	1-51331
Non Fine Focus w/ Coax	1-51324	1-52023	1-51332

NOTE: Zooms using 5 phase stepping motors require user to order the correct cable harness between zoom and controller.

Mounting Options for Motorized Lenses

Navitar also offers flat mounting assemblies for easy integration of our motorized zoom lenses into any application. The flat mounts securely attach to the zoom body using 4 hex screws. Four additional 1/4-20 thru holes are integrated into the mounts to provide a robust attachment point to a machine surface.

6X	12X
1-62572 (Standard)	1-51272 (Standard)
1-64546 (Imperial)	1-52045 (Imperial)
1-64547 (Metric)	1-52046 (Metric)

Coaxial Inputs for Motorized Lenses

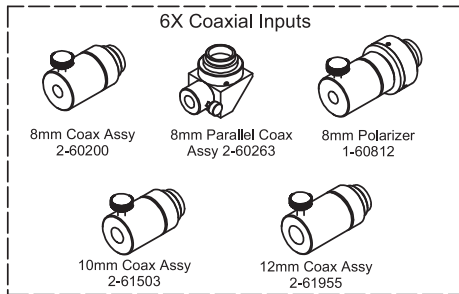

Coaxial Inputs for Zoom 6000	Description and Fiber Input Size
2-60200	8 mm diameter
2-61503	10 mm diameter
2-61955	12 mm diameter
2-60263	8 mm parallel coaxial
1-60812	8 mm polarizer

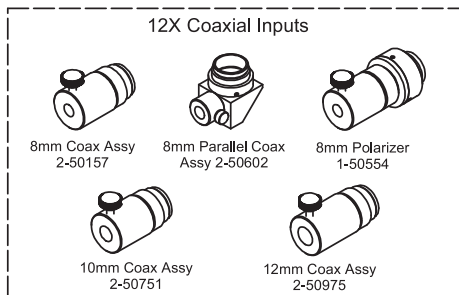

Coaxial Inputs for 12X Zoom	Description and Fiber Input Size
2-50157	8 mm diameter
2-50751	10 mm diameter
2-50975	12 mm diameter
2-50602	8 mm parallel coaxial
1-50554	8 mm polarizer

***Coax parts must be ordered separately for all motorized lenses.**

Motorized Controllers

All Navitar 12X and Zoom 6000 motorized systems can be ordered with a fully integrated control system, featuring single or dual axis control via serial RS-232 or USB.

Software includes Demo Application User Interface “GUI” for simple axis control. Connections are made via two 15-pin high density d-sub connectors. Arrangements can be made for supplying the underlying software code for OEM platform assimilation.

System Requirements

Operating Systems Supported for Serial RS-232 and USB:

- Windows 7, 8.1, 10 (32 & 64 bit)

Computer Requirements:

- Windows Operating System (OS)
- Port: 1 serial or 1 USB port (can be a hub)
- Hard Disk: 1 M bytes
- RAM: Same as OS (if OS works, controller will work)

Available Control Systems

Part #	Description
Board Level	
1-40241	2 phase stepper PCB Kit
1-40167	5 phase stepper PCB Kit
1-40242	Encoded PCB Kit
Enclosures	
1-40233	2 phase flanged enclosure
1-40234	2 phase desktop enclosure
1-40168	5 phase flanged enclosure
1-40169	5 phase desktop enclosure
1-40237	Encoded flanged enclosure
1-40238	Encoded desktop enclosure
Accessories & Power Supplies	
1-40170	5 phase cable harness
8-62503	24V Domestic power supply
8-62501	USB cable (6 feet)
8-62502	RS-232 cable (6 feet)
1-40040	24V Universal Power Supply w/ Plug Kit

Part Number	Output Connector	Input Voltage	Output Voltage	Output Current	Medical Rated	Universal Plug Kit
1-62504	2.1mm x 5.5mm	86-286vAC	24vDC	1.5A		Std. US Plug
8-62503	2.1mm x 5.5mm	120vAC	24vDC	1.05A		Std. US Plug
1-40040	2.1mm x 5.5mm	90-264vAC	24vDC	1.25A	Medical Rated	Yes

High Magnification for Fixed Inspection Applications

Navitar's Precise Eye series of lenses is designed to provide superior optical performance over standard C-mount video lenses.



- High resolution, f/4.5 optical quality for high precision measurement and inspection
- Long working distance makes lighting and handling easier
- Coaxial lighting available for shadow-free illumination
- Compatible with high-magnification infinity corrected objectives
- Mechanically stable for the most demanding vibration environments
- Modular design for flexibility
- Optics attach to any C-mount camera
- Short tube length (~4 inches/101.6mm) and small diameter (1.25 inches/31.8mm)
- Allows for coaxial illumination and/or 3 mm fine focus
- High transmission (>70%) over the visible to near IR spectrum

Precise Eye Field of View Matrix (in mm at nominal working distance)

Lens Attachment	W.D. (mm)	Camera Format & Parameters	0.5X Adapter 1-62088 H x V	0.67X Adapter 1-61453 H x V	1.0X Adapter 1-61445 H x V	1.33X Adapter 1-61448 H x V	2.0X Adapter 1-61450 H x V
0.25X 0.018 NA DOF 1.59 mm 1-6044	310 (nominal)	Mag.	0.23X	0.30X	0.45X	0.60X	0.90X
		1/4" Sensor	14.2 x 10.7	10.6 x 8.0	7.1 x 5.3	5.3 x 4.0	3.6 x 2.7
	282-351 (1) W.D. Range	1/3" Sensor	21.3 x 16.0	15.9 x 11.9	10.7 x 8.0	8.0 x 6.0	5.3 x 4.0
		1/2" Sensor	28.4 x 21.3	21.2 x 15.9	14.2 x 10.7	10.7 x 8.0	7.1 x 5.3
		2/3" Sensor	39.1 x 29.3	29.2 x 21.9	19.6 x 14.7	14.7 x 11.0	9.8 x 7.3
0.5X 0.035 NA DOF 0.40 mm 1-60110	175 (nominal)	Mag.	0.45X	0.60X	0.90X	1.20X	1.80X
		1/4" Sensor	7.1 x 5.3	5.3 x 4.0	3.6 x 2.7	2.7 x 2.0	1.8 x 1.3
	170-190 (1) W.D. Range	1/3" Sensor	10.7 x 8.0	8.0 x 6.0	5.3 x 4.0	4.0 x 3.0	2.7 x 2.0
		1/2" Sensor	14.2 x 10.7	10.6 x 8.0	7.1 x 5.3	5.3 x 4.0	3.6 x 2.7
		2/3" Sensor	19.6 x 14.7	14.6 x 10.9	9.8 x 7.3	7.4 x 5.5	4.9 x 3.7
0.75X 0.054 NA DOF 0.18 mm 1-60111	113 (nominal)	Mag.	0.68X	0.90X	1.35X	1.80X	2.70X
		1/4" Sensor	4.7 x 3.6	3.5 x 2.7	2.4 x 1.8	1.8 x 1.3	1.2 x 0.9
	110-120 (1) W.D. Range	1/3" Sensor	7.1 x 5.3	5.3 x 4.0	3.6 x 2.7	2.7 x 2.0	1.8 x 1.3
		1/2" Sensor	9.5 x 7.1	7.1 x 5.3	4.7 x 3.6	3.6 x 2.7	2.4 x 1.8
		2/3" Sensor	13.0 x 9.8	9.7 x 7.3	6.5 x 4.9	4.9 x 3.7	3.3 x 2.4
None 0.070 NA DOF 0.10 mm	92 (nominal)	Mag.	0.90X	1.21X	1.80X	2.39X	3.60X
		1/4" Sensor	3.6 x 2.7	2.7 x 2.0	1.8 x 1.3	1.3 x 1.0	0.9 x 0.7
	90-93 (1) W.D. Range	1/3" Sensor	5.3 x 4.0	4.0 x 3.0	2.7 x 2.0	2.0 x 1.5	1.3 x 1.0
		1/2" Sensor	7.1 x 5.3	5.3 x 4.0	3.6 x 2.7	2.7 x 2.0	1.8 x 1.3
		2/3" Sensor	9.8 x 7.3	7.3 x 5.5	4.9 x 3.7	3.7 x 2.8	2.4 x 1.8
1.5X 0.106 NA DOF 0.04 mm 1-60112	51 (nominal)	Mag.	1.35X	1.81X	2.70X	3.59X	5.40X
		1/4" Sensor	2.4 x 1.8	1.8 x 1.3	1.2 x 0.9	0.9 x 0.7	0.6 x 0.4
	49-51 (1) W.D. Range	1/3" Sensor	3.6 x 2.7	2.7 x 2.0	1.8 x 1.3	1.3 x 1.0	0.9 x 0.7
		1/2" Sensor	4.7 x 3.6	3.5 x 2.7	2.4 x 1.8	1.8 x 1.3	1.2 x 0.9
		2/3" Sensor	6.5 x 4.9	4.9 x 3.6	3.3 x 2.4	2.4 x 1.8	1.6 x 1.2
2.0X 0.142 NA DOF 0.02 mm 1-60113	36 (nominal)	Mag.	1.80X	2.41X	3.60X	4.79X	7.20X
		1/4" Sensor	1.8 x 1.3	1.3 x 1.0	0.9 x 0.7	0.7 x 0.5	0.4 x 0.3
	35-36 (1) W.D. Range	1/3" Sensor	2.7 x 2.0	2.0 x 1.5	1.3 x 1.0	1.0 x 0.8	0.7 x 0.5
		1/2" Sensor	3.6 x 2.7	2.7 x 2.0	1.8 x 1.3	1.3 x 1.0	0.9 x 0.7
		2/3" Sensor	4.9 x 3.7	3.6 x 2.7	2.4 x 1.8	1.8 x 1.4	1.2 x 0.9

NOTE: (1) Working distance range when using 3 mm fine focus. Field of view will change with shorter or longer working distances.

Precise Eye Performance Specifications

Precise Eye Combinations Lens Attachment + Precise Eye + Adapter	W.D. (mm)	Magnification	NA Object Side	Resolve Limits (µm)	Depth of Field (mm)	Required Matching Pixel Size (µm)
0.25x + Precise Eye + 0.5x	310	0.23x	0.018	18.8	1.59	2.1
0.25x + Precise Eye + 0.67x	310	0.30x	0.018	18.8	1.59	2.8
0.25x + Precise Eye + 1.0x	310	0.45x	0.018	18.8	1.59	4.2
0.25x + Precise Eye + 1.33x	310	0.60x	0.018	18.8	1.59	5.6
0.25x + Precise Eye + 2.0x	310	0.90x	0.018	18.8	1.59	8.4
0.5x + Precise Eye + 0.5x	175	0.45x	0.035	9.4	0.40	2.1
0.5x + Precise Eye + 0.67x	175	0.60x	0.035	9.4	0.40	2.8
0.5x + Precise Eye + 1.0x	175	0.90x	0.035	9.4	0.40	4.2
0.5x + Precise Eye + 1.33x	175	1.20x	0.035	9.4	0.40	5.6
0.5x + Precise Eye + 2.0x	175	1.80x	0.035	9.4	0.40	8.4
0.75x + Precise Eye + 0.5x	113	0.68x	0.054	6.2	0.18	2.1
0.75x + Precise Eye + 0.67x	113	0.90x	0.054	6.2	0.18	2.8
0.75x + Precise Eye + 1.0x	113	1.35x	0.054	6.2	0.18	4.2
0.75x + Precise Eye + 1.33x	113	1.80x	0.054	6.2	0.18	5.6
0.75x + Precise Eye + 2.0x	113	2.70x	0.054	6.2	0.18	8.4
None + Precise Eye + 0.5x	92	0.90x	0.071	4.6	0.10	2.1
None + Precise Eye + 0.67x	92	1.21x	0.071	4.6	0.10	2.8
None + Precise Eye + 1.0x	92	1.80x	0.071	4.6	0.10	4.2
None + Precise Eye + 1.33x	92	2.39x	0.071	4.6	0.10	5.6
None + Precise Eye + 2.0x	92	3.60x	0.071	4.6	0.10	8.4
1.5x + Precise Eye + 0.5x	51	1.35x	0.106	3.2	0.04	2.1
1.5x + Precise Eye + 0.67x	51	1.81x	0.106	3.2	0.04	3.0
1.5x + Precise Eye + 1.0x	51	2.70x	0.106	3.2	0.04	4.4
1.5x + Precise Eye + 1.33x	51	3.59x	0.106	3.2	0.04	5.8
1.5x + Precise Eye + 2.0x	51	5.40x	0.106	3.2	0.04	8.6
2.0x + Precise Eye + 0.5x	36	1.80x	0.142	2.4	0.02	2.1
2.0x + Precise Eye + 0.67x	36	2.41x	0.142	2.4	0.02	2.8
2.0x + Precise Eye + 1.0x	36	3.60x	0.142	2.4	0.02	4.2
2.0x + Precise Eye + 1.33x	36	4.79x	0.142	2.4	0.02	5.6
2.0x + Precise Eye + 2.0x	36	7.20x	0.142	2.4	0.02	8.4

Assumptions:

1. Minimum resolvable feature size is half of the threshold line pair limit. Calculation = $1/(3000 \times \text{Lens NA})$
2. Matching pixel size is that which will permit the minimum feature size to overlap two pixels. Calculation = $1/2(\text{Feature Size} \times \text{System Magnification})$
3. If the matching pixel size is greater than the camera pixel size, the system is "lens limited.", if it's less than the camera pixel size, the system is "camera limited."

Greater Resolution and Magnification

Navitar offers a variety of Ultra Precise Eye systems ideal for high magnification applications. The advanced design produces outstanding contrast and precision, while providing higher resolution and magnification than the standard Precise Eye. These systems incorporate infinity corrected objectives to provide long working distances and excellent edge flatness and clarity. The Ultra Precise Eye is also available with fine focus (1-61521) or with fine focus and coaxial illumination (1-61522).



Ultra Precise Eye Magnification Matrix (in mm)

Infinity Corrected Objective	W.D. (mm)	Camera Format & Parameters	0.5X Adapter 1-62088 H x V	0.67X Adapter 1-61453 H x V	1.0X Adapter 1-61445 H x V	1.33X Adapter 1-61448 H x V	2.0X Adapter 1-61450 H x V
4X 0.20 NA 1-55341	20	Mag.	1.78X	2.39X	3.56X	4.73X	7.12X
		1/4" Sensor	1.80 x 1.35	1.34 x 1.01	0.90 x 0.67	0.68 x 0.51	0.45 x 0.34
		1/3" Sensor	2.70 x 2.02	2.01 x 1.51	1.35 x 1.01	1.01 x 0.76	0.67 x 0.51
		1/2" Sensor	3.60 x 2.70	2.68 x 2.01	1.80 x 1.35	1.35 x 1.01	0.90 x 0.67
		2/3" Sensor	-	-	2.47 x 1.85	1.86 x 1.39	1.24 x 0.93
5X 0.14 NA 1-60226	34	Mag.	2.23X	2.98X	4.45X	5.92X	8.90X
		1/4" Sensor	1.44 x 1.08	1.07 x 0.80	0.72 x 0.54	0.54 x 0.41	0.36 x 0.27
		1/3" Sensor	2.16 x 1.62	1.61 x 1.21	1.08 x 0.81	0.81 x 0.61	0.54 x 0.40
		1/2" Sensor	2.88 x 2.16	2.15 x 1.61	1.44 x 1.08	1.08 x 0.81	0.72 x 0.54
		2/3" Sensor	-	-	1.98 x 1.48	1.49 x 1.12	0.99 x 0.74
10X 0.28 NA 1-60227	33	Mag.	4.45X	5.96X	8.90X	11.80X	17.80X
		1/4" Sensor	0.72 x 0.54	0.54 x 0.40	0.36 x 0.27	0.27 x 0.20	0.18 x 0.13
		1/3" Sensor	1.08 x 0.81	0.80 x 0.60	0.54 x 0.40	0.41 x 0.30	0.27 x 0.20
		1/2" Sensor	1.44 x 1.08	1.07 x 0.80	0.72 x 0.54	0.54 x 0.41	0.36 x 0.27
		2/3" Sensor	-	-	0.99 x 0.74	0.74 x 0.56	0.49 x 0.37
20X 0.42 NA 1-60228	20	Mag.	8.90X	11.90X	17.80X	23.70X	35.60X
		1/4" Sensor	0.36 x 0.27	0.27 x 0.20	0.18 x 0.13	0.14 x 0.10	0.09 x 0.07
		1/3" Sensor	0.54 x 0.40	0.40 x 0.30	0.27 x 0.20	0.20 x 0.15	0.13 x 0.10
		1/2" Sensor	0.72 x 0.54	0.54 x 0.40	0.36 x 0.27	0.27 x 0.20	0.18 x 0.13
		2/3" Sensor	-	-	0.49 x 0.37	0.37 x 0.28	0.25 x 0.19
50X 0.55 NA 1-60229	13	Mag.	22.30X	29.80X	44.50X	59.20X	89.00X
		1/4" Sensor	0.14 x 0.11	0.11 x 0.08	0.07 x 0.05	0.05 x 0.04	0.04 x 0.03
		1/3" Sensor	0.22 x 0.16	0.16 x 0.12	0.11 x 0.08	0.08 x 0.06	0.05 x 0.04
		1/2" Sensor	0.29 x 0.22	0.21 x 0.16	0.14 x 0.11	0.11 x 0.08	0.07 x 0.05
		2/3" Sensor	-	-	0.20 x 0.15	0.15 x 0.11	0.10 x 0.07

NOTE: The O-I remains constant for each body tube (main assembly) regardless of which infinity corrected objective and adapter are selected: 1-61517 I-O = 219 mm, 1-61521 I-O = 243 mm, 1-61522 I-O = 263 mm. NA varies with zoom setting.

Precise Eye with Co-axial Illumination

Navitar's Precise Eye with Internal Co-axial Illumination (1-61446) is an ideal solution for applications involving highly reflective surfaces, such as wafers, polished samples, and fluids. Designed to provide even illumination for higher magnification applications, coaxial illumination provides extremely detailed resolution, particularly when a high resolution camera is used.

Precise Eye Field of View Matrix for Co-axial Illumination (in mm at nominal working distance)

Lens Attachment	W.D. (mm)	Camera Format & Parameters	0.5X Adapter 1-62088 H x V	0.67X Adapter 1-61453 H x V	1.0X Adapter 1-61445 H x V	1.33X Adapter 1-61448 H x V	2.0X Adapter 1-61450 H x V
0.5X 0.035 NA DOF 0.40 mm 1-60110	175 (nominal)	Mag.	0.45X	0.60X	0.90X	1.20X	1.80X
		1/4" Sensor	7.1 x 5.3	5.3 x 4.0	3.6 x 2.7	2.7 x 2.0	1.8 x 1.3
	170-190 (1) W.D. Range	1/3" Sensor	10.7 x 8.0*	8.0 x 6.0	5.3 x 4.0	4.0 x 3.0	2.7 x 2.0
		1/2" Sensor	14.2 x 10.7*	10.6 x 8.0*	7.1 x 5.3	5.3 x 4.0	3.6 x 2.7
		2/3" Sensor	19.6 x 14.7*	14.6 x 10.9*	9.8 x 7.3*	7.4 x 5.5	4.9 x 3.7*
0.75X 0.054 NA DOF 0.17 mm 1-60111	113 (nominal)	Mag.	0.68X	0.90X	1.35X	1.80X	2.70X
		1/4" Sensor	4.7 x 3.6	3.5 x 2.7	2.4 x 1.8	1.8 x 1.3	1.2 x 0.9
	110-120 (1) W.D. Range	1/3" Sensor	7.1 x 5.3	5.3 x 4.0	3.6 x 2.7	2.7 x 2.0	1.8 x 1.3
		1/2" Sensor	9.5 x 7.1*	7.1 x 5.3	4.7 x 3.6	3.6 x 2.7	2.4 x 1.8
		2/3" Sensor	13.0 x 9.8*	9.7 x 7.3*	6.5 x 4.9	4.9 x 3.7	3.3 x 2.4*
None 0.070 NA DOF 0.10 mm	92 (nominal)	Mag.	0.90X	1.21X	1.80X	2.39X	3.60X
		1/4" Sensor	3.6 x 2.7	2.7 x 2.0	1.8 x 1.3	1.3 x 1.0	0.9 x 0.7
	90-93 (1) W.D. Range	1/3" Sensor	5.3 x 4.0	4.0 x 3.0	2.7 x 2.0	2.0 x 1.5	1.3 x 1.0
		1/2" Sensor	7.1 x 5.3	5.3 x 4.0	3.6 x 2.7	2.7 x 2.0	1.8 x 1.3
		2/3" Sensor	9.8 x 7.3*	7.3 x 5.5*	4.9 x 3.7	3.7 x 2.8	2.4 x 1.8*
1.5X 0.106 NA DOF 0.046 mm 1-60112	51 (nominal)	Mag.	1.35X	1.81X	2.70X	3.59X	5.40X
		1/4" Sensor	2.4 x 1.8	1.8 x 1.3	1.2 x 0.9	0.9 x 0.7	0.6 x 0.4
	49-51 (1) W.D. Range	1/3" Sensor	3.6 x 2.7	2.7 x 2.0	1.8 x 1.3	1.3 x 1.0	0.9 x 0.7
		1/2" Sensor	4.7 x 3.6	3.5 x 2.7	2.4 x 1.8	1.8 x 1.3	1.2 x 0.9
		2/3" Sensor	6.5 x 4.9	4.9 x 3.6*	3.3 x 2.4	2.5 x 1.8	1.6 x 1.2*
2.0X 0.142 NA DOF 0.025 mm 1-60113	36 (nominal)	Mag.	1.80X	2.41X	3.60X	4.79X	7.20X
		1/4" Sensor	1.8 x 1.3	1.3 x 1.0	0.9 x 0.7	0.7 x 0.5	0.4 x 0.3
	35-36 (1) W.D. Range	1/3" Sensor	2.7 x 2.0	2.0 x 1.5	1.3 x 1.0	1.0 x 0.8	0.7 x 0.5
		1/2" Sensor	3.6 x 2.7	2.7 x 2.0	1.8 x 1.3	1.3 x 1.0	0.9 x 0.7
		2/3" Sensor	4.9 x 3.7	3.6 x 2.7*	2.4 x 1.8	1.8 x 1.4	1.2 x 0.9*

NOTE:

*The internal coax will illuminate a circular area of about 11 mm in diameter. Any field of view larger than 11 mm will have darkened corners.
(1) Working distance range when using 3 mm fine focus. Field of view will change with shorter or longer working distance.

PRECISE EYE SYSTEM DIAGRAM

Adapter Tubes



Ultra Body Tubes

Ultra Motorized Body Tubes

Right Angle Body Tubes

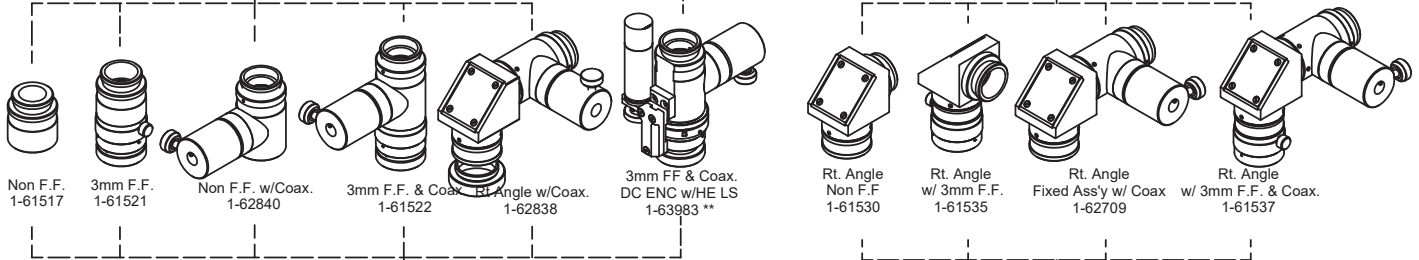

Infinity Corrected Objectives

Mitutoyo

Motic

Navitar

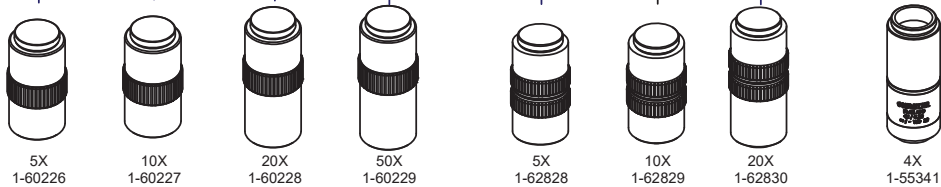

* Included with ULTRA PRECISE EYE

** Items are Special Order (Contact Navitar for Additional Information)

Adapter Plates

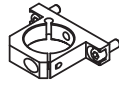

Mounting Clamp
1-61510

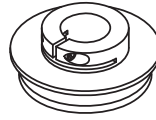

(76mm)
1-61662

Standard Body Tubes



Non F.F.
1-61456



3mm F.F.
w/ Aperture
1-62473



3mm F.F.
1-61449



Non F.F.
w/ Coax
1-62707



3mm F.F.
w/ Coax.
1-61446

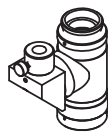

3mm F.F.
w/ Rt. Ang. Coax
1-62247

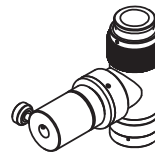

Polarizer/Analyzer
w/ 3mm F.F.
1-61817

Motorized Body Tubes

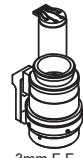

3mm F.F.
2 PhaseStepper
w/ HE Limits
1-62693**

Lens Attachments



0.25X
1-6044



0.5X
1-60110



0.75X
1-60111



1.5X
1-60112



2X
1-60113

High-Mag Microscopy Solution

The NUV-VIS Zoom is a motorized imaging lens system that operates within a spectral range of 330nm to 700nm and offers a 6.2:1 zoom ratio. It is an ideal digital imaging solution for high magnification microscopy and OEM applications such as protein crystallography, forensic evidence analysis and surface defect inspection.

- Designed for a 2/3" sensor
- Focal length range of 80-497mm
- Motorized for easy magnification adjustments
- Combine with infinity corrected imaging microscope objectives, Plan Apo NUV long working distance microscope objectives, and high power UV focusing objectives
- Operates within 330nm to 700nm spectral range
- Can be modified for manual actuation



Zoom Ratio	6.2:1
Magnification	0.4x - 2.5x
Focal Length Range (mm)	80 - 497
Spectral Range (nm)	330 - 700
NA: Image Side	0.019 - 0.024
Distortion	< 0.2% across entire field
Max. Sensor Coverage	2/3"
Camera Mount	C-Mount
Zoom Drive Mechanism	2 Phase Stepping Motor Hall-Effect Limit Sensors

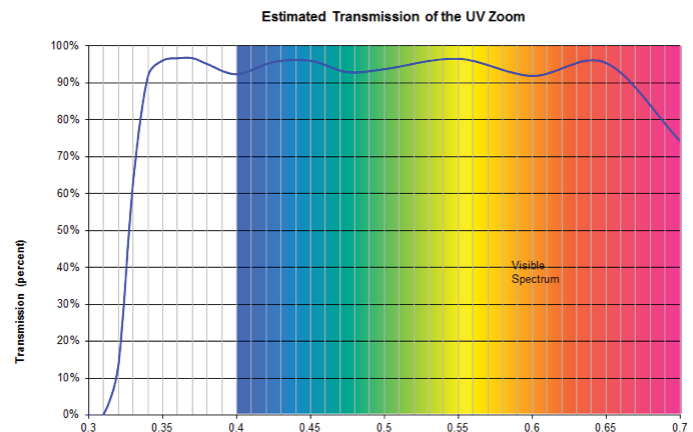

Objective Lens (Mitutoyo) Plan Apo NUV	Working Distance (mm)	NA	Depth of Field (μm)	Camera Format	1.0X Adapter Low Mag HxV	1.0X Adapter High Mag HxV
10X	30.5	0.28	6.4	Mag	4.0X	24.9X
				1/4" Sensor	0.80 x 0.60	0.13 x 0.10
				1/3" Sensor	1.20 x 0.90	0.19 x 0.14
				1/2" Sensor	1.60 x 1.20	0.26 x 0.19
				2/3" Sensor	2.20 x 1.65	0.35 x 0.27
20X	17.0	0.40	3.1	Mag	8.0X	49.7X
				1/4" Sensor	0.40 x 0.30	0.06 x 0.05
				1/3" Sensor	0.60 x 0.45	0.10 x 0.07
				1/2" Sensor	0.80 x 0.60	0.13 x 0.10
				2/3" Sensor	1.10 x 0.83	0.18 x 0.13
50X	15.0	0.42	0.8	Mag	20.0X	124.3X
				1/4" Sensor	0.16 x 0.12	0.03 x 0.02
				1/3" Sensor	0.24 x 0.18	0.04 x 0.03
				1/2" Sensor	0.32 x 0.24	0.05 x 0.04
				2/3" Sensor	0.44 x 0.33	0.07 x 0.05

NUV-VIS ZOOM SYSTEM DIAGRAM

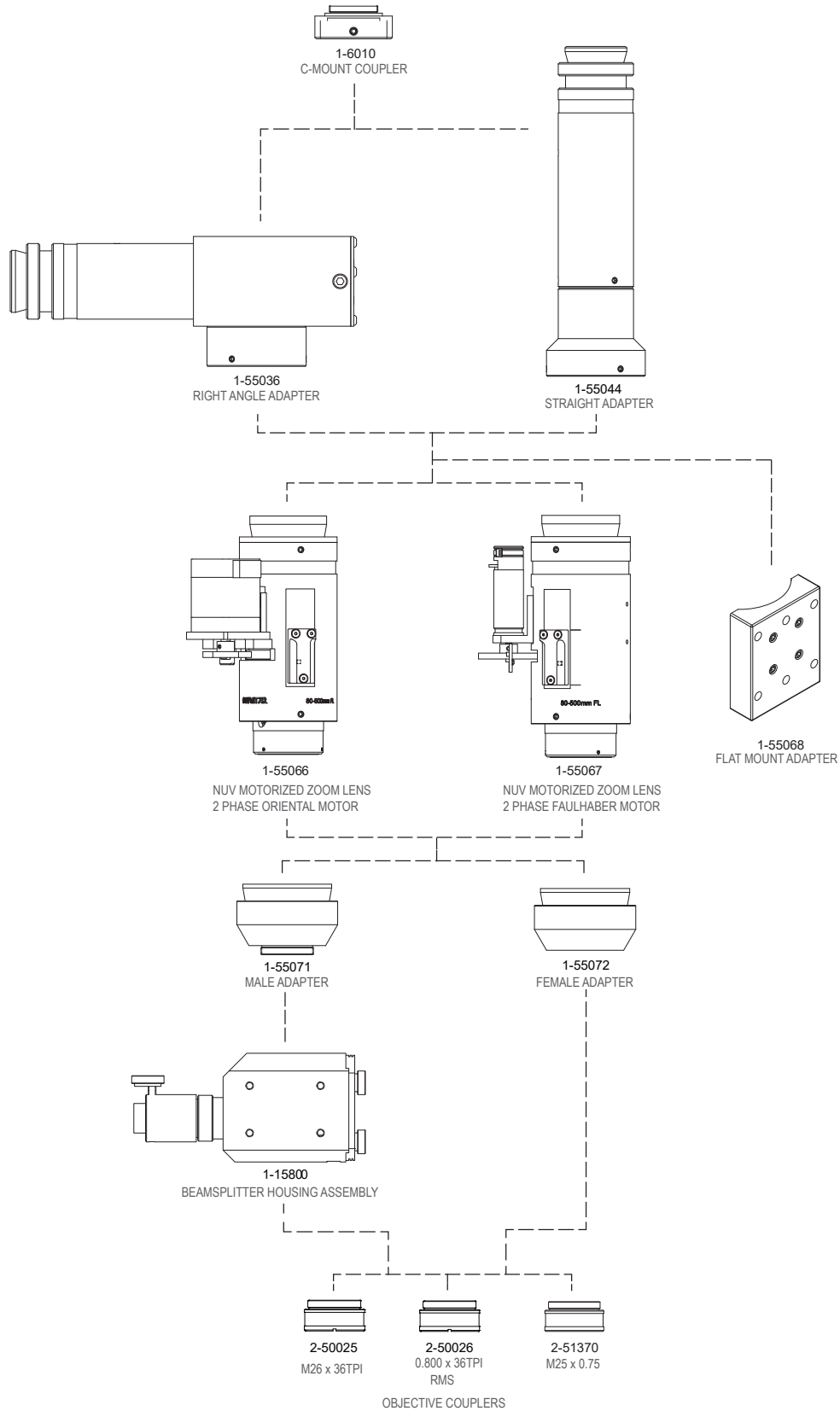

DUAL VIEW LENS SYSTEM DIAGRAM

Adapter Tube Required
(1-6015 or 1-6218 suggested)

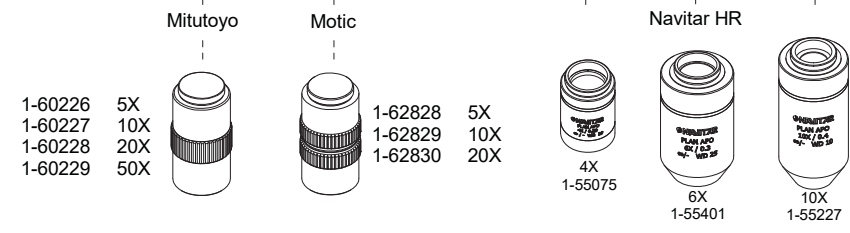
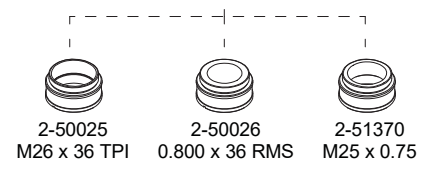
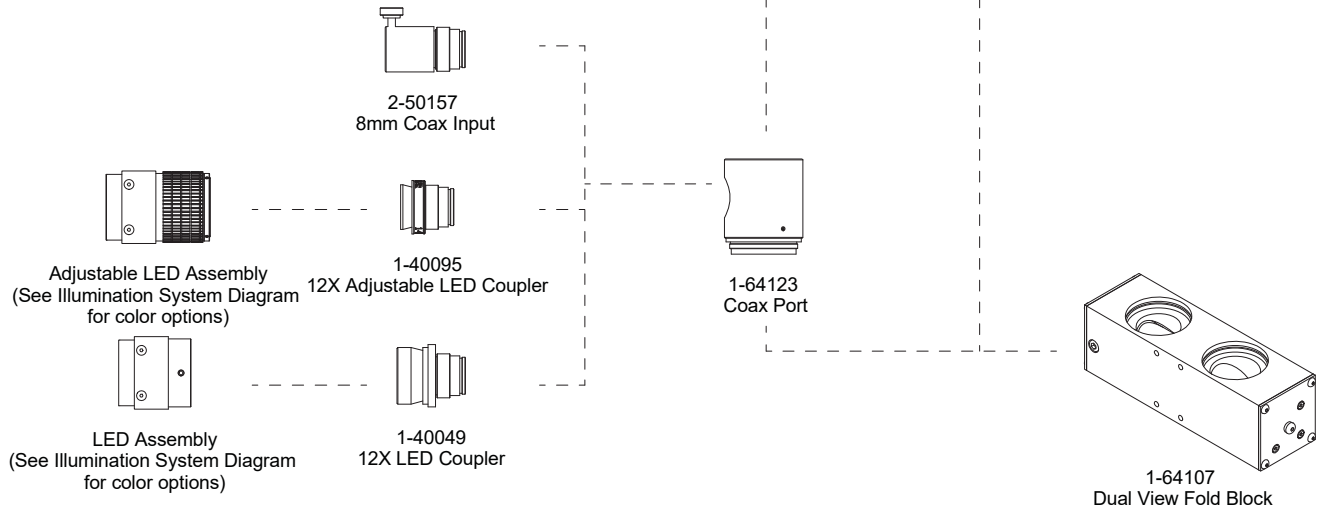
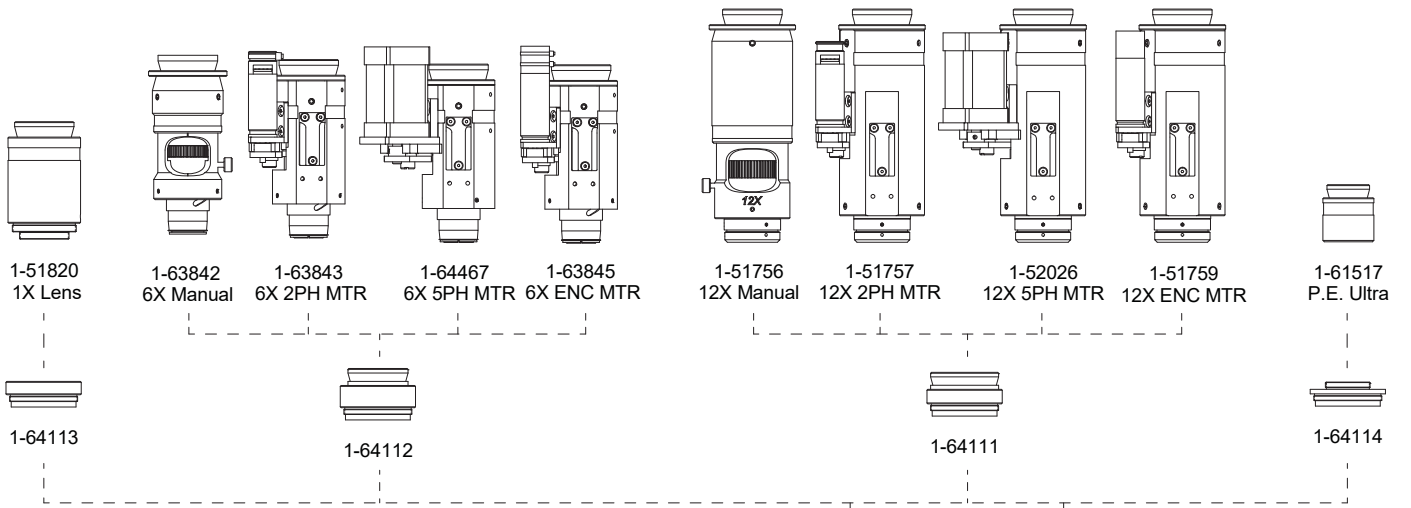

Note: Factory alignment of all parts is required.

DUAL VIEW LENS SYSTEM DIAGRAM

Adapter Tube Required
(1-6015 or 1-6218 suggested)

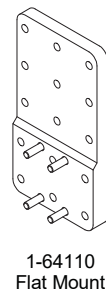
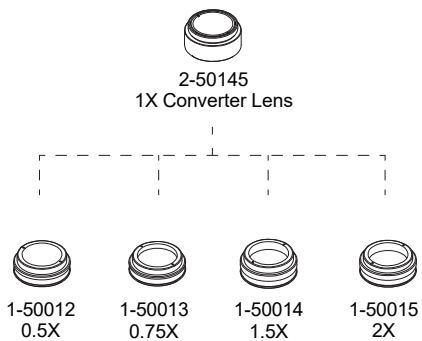
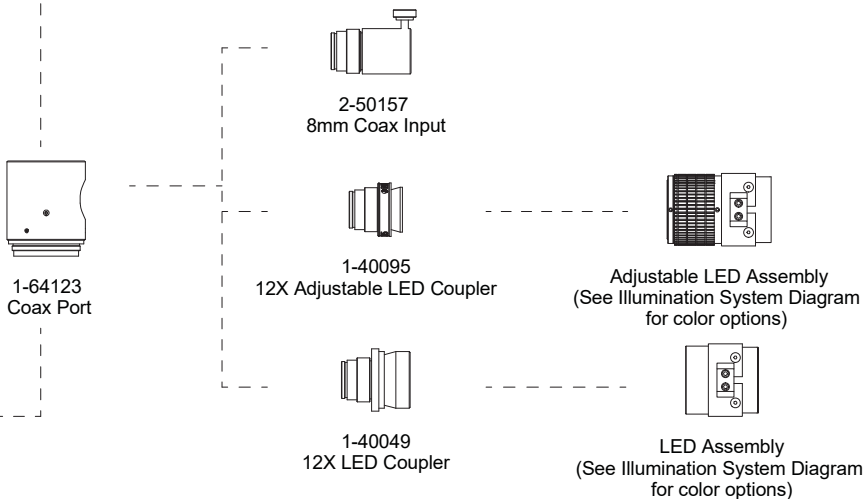
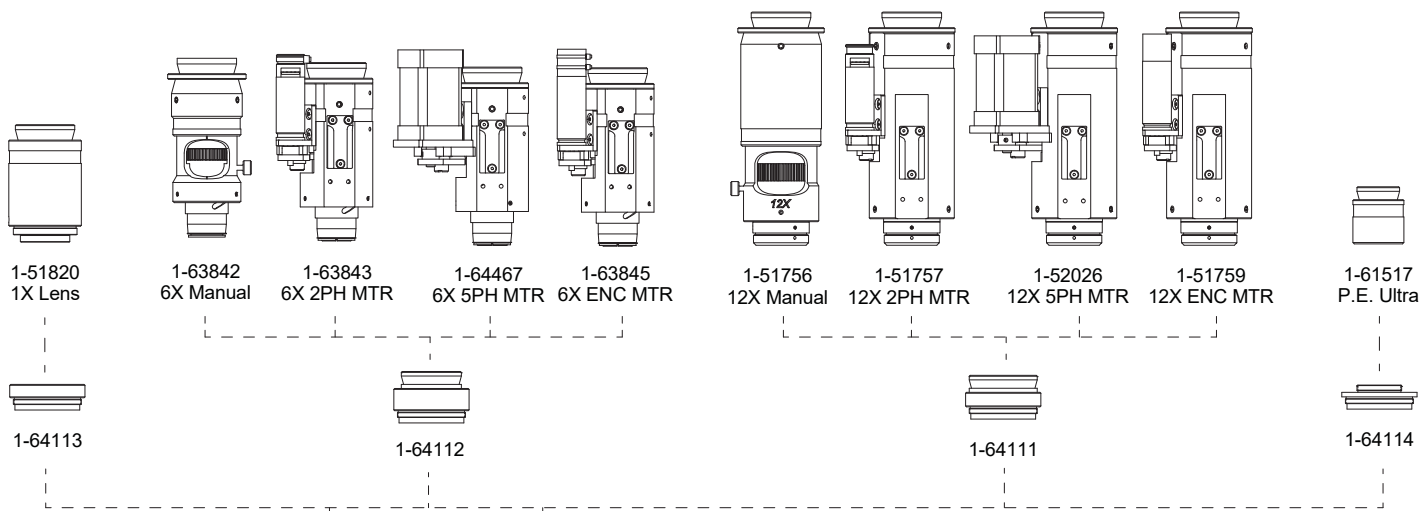

MODULAR TUBE LENS SYSTEM DIAGRAM

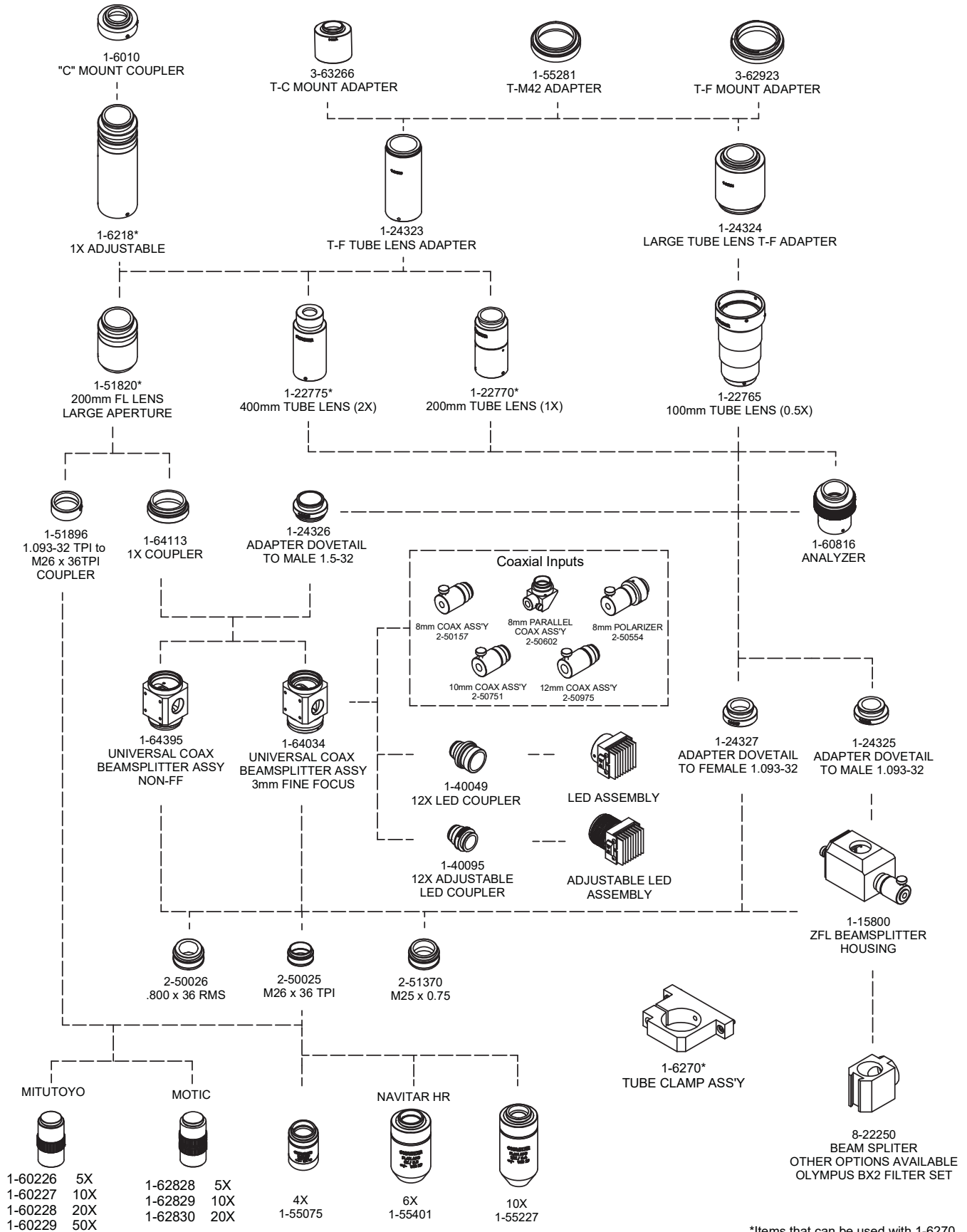

*Items that can be used with 1-6270

Navitar's new line of modular tube lenses offer the ideal optical solution for OEM and research imaging and measurement applications including metrology, flat panel inspection and cell imaging.

- 200mm focal length design for use with infinity corrected objectives
- 0.5x, 1x and 2x magnification modular tube lenses will cover camera sensors from 11-33mm
- 2 and 3 position objective changer available for using multiple objectives and magnifications
- Use with Brightfield, Transmitted, Reflected, and Köhler illumination techniques for high resolution images
- Perfect for industrial and life science applications



MTL Field of View Matrix

Objective Lens	Working Distance (mm)	Camera Formats / Parameters	0.5X Tube Lens H x V	1.0X Tube Lens H x V	2.0X Tube Lens H x V
2X Navitar		2/3" Sensor	8.80 x 6.60	4.40 x 3.30	2.20 x 1.65
		1" Sensor	-	6.40 x 4.80	3.20 x 2.40
		4/3" Sensor	-	8.65 x 6.50	4.33 x 3.25
		33mm	-	-	6.60 x 4.95
4X Navitar	20	2/3" Sensor	4.40 x 3.30	2.20 x 1.65	1.10 x 0.82
		1" Sensor	-	3.20 x 2.40	1.60 x 1.20
		4/3" Sensor	-	4.60 x 3.45	2.30 x 1.70
		33mm	-	-	3.30 x 2.40
5X Mitutoyo	34	2/3" Sensor	3.52 x 2.64	1.76 x 1.32	0.88 x 0.66
		1" Sensor	-	2.56 x 1.92	1.28 x 0.96
		4/3" Sensor	-	3.46 x 2.60	1.73 x 1.30
		33mm	-	-	2.64 x 1.99
10X Mitutoyo	33.5	2/3" Sensor	1.76 x 1.32	0.88 x 0.66	0.44 x 0.33
		1" Sensor	-	1.28 x 0.96	0.64 x 0.48
		4/3" Sensor	-	1.73 x 1.30	0.87 x 0.65
		33mm	-	-	1.32 x 0.99
20X Mitutoyo	20	2/3" Sensor	0.88 x 0.66	0.44 x 0.33	0.22 x 0.16
		1" Sensor	-	0.64 x 0.48	0.32 x 0.24
		4/3" Sensor	-	0.87 x 0.65	0.43 x 0.32
		33mm	-	-	0.66 x 0.49
50X Mitutoyo	13	2/3" Sensor	0.36 x 0.26	0.18 x 0.13	0.09 x 0.06
		1" Sensor	-	0.26 x 0.19	0.13 x 0.09
		4/3" Sensor	-	0.35 x 0.26	0.17 x 0.13
		33mm	-	-	0.26 x 0.19

Perfect for life science fluorescent imaging and industrial applications. Ask your sales representative for more details.

High Resolution Plan Apochromat Infinity Corrected Objective Lenses

Ideal for industrial imaging applications

Navitar HR plan apochromatic objectives offer high NA, large FOV, and working distances ranging from 10-39mm.

The objective series includes 1X, 2X, 4X, 6X, and 10X resolutions.

- Designed with a parfocal distance of 95mm to be compatible with turret applications
- Apochromatic over 436-656 nm, providing excellent correction of spherical and chromatic aberrations.



	High NA / Long W. D.		High NA / Large FOV		
	1X*	2X*	4X HR	6X HR	10X HR
Part Numbers	1-55282	1-55273	1-55341	1-55343	1-55227
Numerical Aperture	0.04	0.08	0.2	0.3	0.4
Working Distance (mm)	15	39	20	25	10
Focal Length (mm)	200	100	50	33.3	20
Resolving Power	8.3 μm	4.2 μm	1.7 μm	1.1 μm	0.8 μm
Depth of Field	$\pm 160 \mu\text{m}$ (320 μm Range)	$\pm 40 \mu\text{m}$ (80 μm Range)	$\pm 6.8 \mu\text{m}$ (13.6 μm Range)	$\pm 3.05 \mu\text{m}$ (6.1 μm Range)	$\pm 1.6 \mu\text{m}$ (3.2 μm Range)
Field Number	22	22	22	22	22
Compatible Tube Lens	EFL=200mm	EFL=200mm	EFL=200mm	EFL=200mm	EFL=200mm
Parfocal Length (mm)	95	95	95	95	95
Mounting Threads	M26 x 36 TPI	M26 x 36 TPI	M26 x 36 TPI	M26 x 36 TPI	M26 x 36 TPI
Wavelength Range	436nm - 656nm	436nm - 656nm	486nm - 656nm	436nm - 656nm	436nm - 656nm
Availability	call for availability	call for availability	In Stock	In Stock	In Stock

* Only available in OEM quantities by special order

4K HDR Lenses

Navitar offers compact, lightweight, HDR wide angle lenses designed for use with 12-16 Megapixel 1" format cameras with a 2.4um or 3.45um pixel pitch. The Centaur and Unicorn lenses are athermal over the operating temperature range and capable of day-night band operation 450nm to 850nm simultaneously.

- All glass construction
- Rectilinear distortion correction (Falcon Narrow & Dragon Narrow)
- F- Θ distortion (Falcon & Unicorn)
- Telecentric
- Athermal operation
- Superior stray light rejection
- Optimized for HDR imaging applications
- Survival temperature range -40C to +70C
- Operating temperature range -20C to +50C



	Dragon Wide	Dragon Narrow	Falcon Wide	Falcon Narrow
Imager Format	1" (4K compatible)	1" (4K compatible)	1" (4K compatible)	1" (4K compatible)
Focal Length	9.50mm	17.75mm	7.10mm	18.75mm
F/#	1.8	1.8	2.4	2.8
Total Track Length (TTL)	125.0mm	125.0mm	55.0mm	55.0mm
Image Circle (nominal)	16.0mm	16.0mm	16.0mm	16.0mm
Field of View	96.5° diagonal	50.7° diagonal	112.0° diagonal	47.1° diagonal
Distortion (F-Theta / Rectilinear)	<0.5%	<2.4%	<0.5%	<1.0%
Relative Illumination	>85%	>80%	>85%	>80%
Resolution	On axis: >208lp/mm S&T Field Edge: > 208lp/mm S&T	On axis: >208lp/mm S&T Field Edge: > 208lp/mm S&T	On axis: >200lp/mm S&T Field Edge: > 140lp/mm S&T	On axis: >200lp/mm S&T Field Edge: > 200lp/mm S&T
Chief Ray Angle	<2° at 8.0mm image circle	<2° at 8.0mm image circle	<4° at 8.0mm image circle	<4° at 8.0mm image circle
IR Filter	Included	Included	Included	Included
Stray Light Rejection	< 1E10-4 (In-field) < 1E10-5 (Out-of-field)	< 1E10-4 (In-field) < 1E10-5 (Out-of-field)	< 1E10-4 (In-field) < 1E10-5 (Out-of-field)	< 1E10-4 (In-field) < 1E10-5 (Out-of-field)
Focus Stability	Athermal	Athermal	Athermal	Athermal

Illumination Products

Navitar offers LED ring lights, Brightlight LED coaxial illuminators, fiber optic illuminators, and power supplies.

Fiber Optic Lighting

These fiber optic illuminators consist of a Halogen illumination system with a variable light intensity control. They accept a single or dual light pipe or an attachable ring light for illuminating a wider area. These illuminators offer low operating temperature and low noise output.

Available Fiber Optic Accessories

Model	Description
1-6192	Ring light w/ 1.28" inside diameter, 0.5" input ferrule, 3 foot length (Also available in 6ft, 8ft, 10ft and 15ft lengths)
1-61214	Ring light w/ 1.28" inside diameter, 0.718" input ferrule, 3 foot length (Also available in 6ft and 8ft lengths)
1-60926	Ring light w/ 4.5" inside diameter, 0.718" input ferrule, 3 foot length
2-50017	Ring light adapter for any 12X with fine focus
1-60106	Flexible light pipe for co-axial, 0.5" input ferrule, 3 foot length (Also available in 6ft, 8ft, 10ft, 12ft and 15ft lengths)
1-60162	Flexible light pipe for co-axial, 0.718" input ferrule, 3 foot length (Also available in 6ft, 8ft and 12ft lengths)
1-6267	2" x 2" fiber optic back light, 0.718" input ferrule, 40" length
8-61313	Dual gooseneck, 0.718" input ferrule
1-60787	Coupler to convert 0.5" input ferrule to 0.718" input ferrule
EKE	Long-life replacement lamp; 200 hour life, 21V, 3250° K
EJV	Standard replacement lamp; 40 hour life, 21V, 3350° K

Fiber Optics Power Supplies

Navitar offers a selection of compact, rugged, AC/DC Halogen light sources with solid state dimmers for variable light intensity and maximum lamp life.

Model	Description
8-61172	120 volt fiber optic power supply, 150w EKE lamp, 0.720" fiber receptacle (CSA, UL, CE compliant)
1-60563	220 volt fiber optic power supply, 150w EKE lamp, 0.720" fiber receptacle (CSA, UL, CE compliant)
8-61892	90-265 volt DC regulated fiber optic power supply, 150w EKE lamp, 0.720" fiber receptacle (CSA, UL, CE compliant)
1-63720	Light Source DC regulated 150W, 120/220V. CSA and CE certified.

Internal Coaxial Input Ports

For Zoom 6000	Description
2-60200	8 mm diameter fiber input
2-61503	10 mm diameter fiber input
2-61955	12 mm diameter fiber input
2-60263	8 mm diameter input parallel coaxial
1-60812	8 mm diameter input polarizer
For 12X Zoom	Description
2-50157	8 mm diameter fiber input
2-50751	10 mm diameter fiber input
2-50975	12 mm diameter fiber input
2-50602	8 mm diameter input parallel coaxial
1-50554	8 mm diameter input polarizer

LED Illumination

Two LED based products are available from Navitar: Brightlight coaxial illuminators and Ring Light illuminators. Designed to match the optical performance of our vision systems, each illumination system was created to work with a specific system, such as Navitar's Zoom 6000, 12X Zoom or Precise Eye system. Each lighting component incorporates the correct number of individual LEDs, placed in the optimal optical position, to provide powerful, even illumination across a given field of view.

Benefits Include:

- Longer life
- Minimum power loss
- Narrow wavelength band (red), constant color temperature (white)
- Small packaging with optimal heat management
- No fan vibration
- Lower cost



Navitar can manufacture fiber bundles and ring lights in any length. Please contact Navitar directly with your specific requirements.



RING LIGHT SYSTEMS

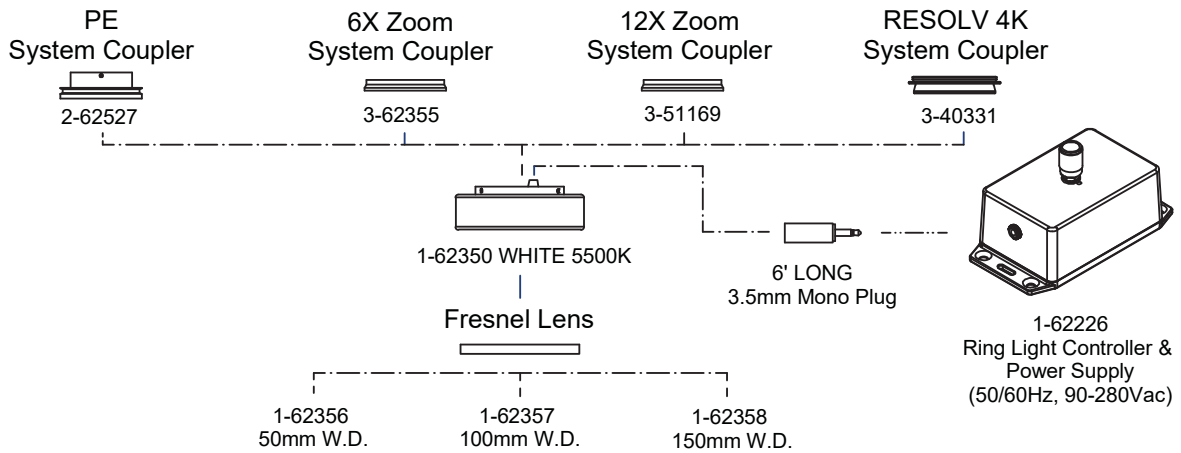

ADJUSTABLE COAXIAL LED ASSEMBLIES

ILLUMINATORS:

- 1-40086 NEUTRAL WHITE (4100K*)
- 1-40087 COOL WHITE (6500K*)
- 1-40088 WARM WHITE (3100K*)
- 1-40089 GREEN (530nm*)
- 1-40090 CYAN (505nm*)
- 1-40091 BLUE (470nm*)
- 1-40092 ROYAL BLUE (447.5nm*)
- 1-40106 RED (627nm*)
- 1-40093 RED-ORANGE (617nm*)
- 1-40094 AMBER (590nm*)

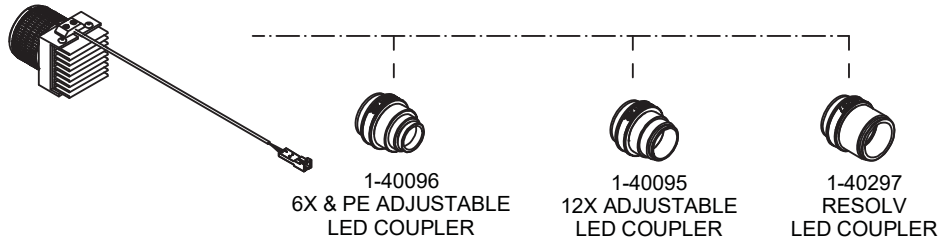

BRIGHTLIGHT LED ASSEMBLIES

ILLUMINATORS:

- 1-40028 NEUTRAL WHITE (4100K*)
- 1-40029 COOL WHITE (6500K*)
- 1-40030 WARM WHITE (3100K*)
- 1-40031 GREEN (530nm*)
- 1-40032 CYAN (505nm*)
- 1-40033 BLUE (470nm*)
- 1-40034 ROYAL BLUE (447.5nm*)
- 1-40035 RED (627nm*)
- 1-40036 RED- ORANGE (617nm*)
- 1-40037 AMBER (590nm*)

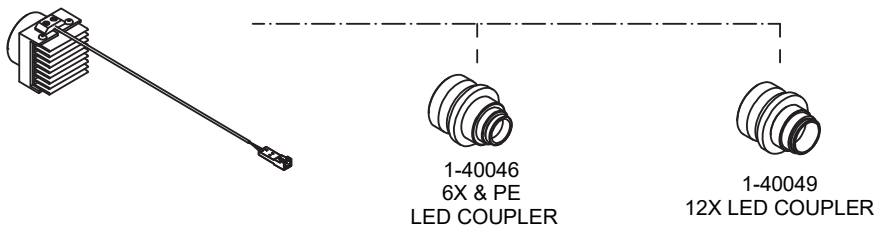

CONTROLLERS

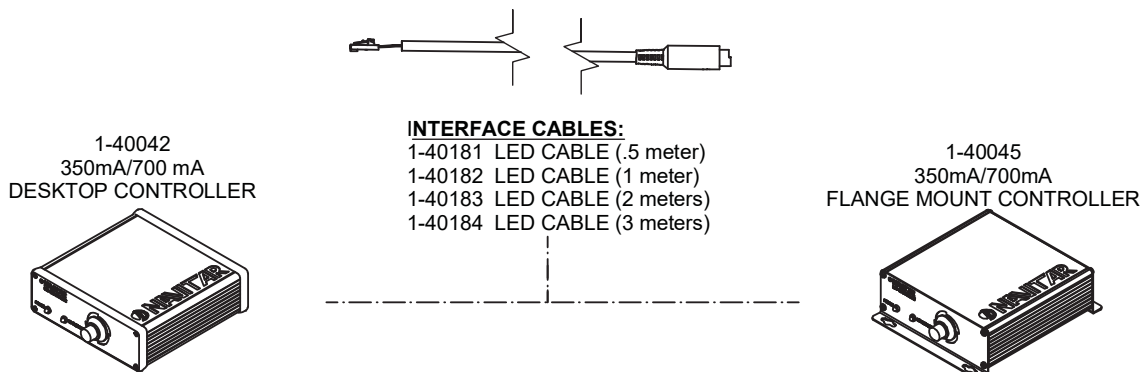

Values are typical. See website for tolerances
 *** USB / RS-232 CABLES & POWER SUPPLY INCLUDED ***

Large Format Lenses

Navitar's large format lenses, including brands like Kowa and Zeiss, meet the demands for high center to edge resolution, low distortion, and application specific F-numbers. These lenses are not modified video lenses; they are designed to match the performance abilities of high-end megapixel type cameras.



Navitar Lenses

25mm Platinum Lens

Our innovative 25 mm multi-magnification lens (1-15838) works with F-mount or C-mount cameras and offers 200 line pairs per millimeter resolution. Ideal for vision system applications, this wide-angle lens is designed to allow cameras to inspect large areas without the great distance required by a typical lens.

Navitar's 25 mm lens features a fixed F/8 aperture which allows for a balance between depth of field and resolution while maintaining significant light-gathering power. It has 42 mm image coverage and a depth of field ranging from 15.4 mm at 0.1X to 1.1 mm at 0.5X. Its low distortion permits cameras to determine dimensional measurements without the need for software calibration on vision systems.

25 mm Platinum Lens Features

- Magnification from 0.1X to 0.5X
- Focusable from 2" to infinity
- 0.13% distortion on edges
- Wide field design for close-up imaging
- Large depth of field
- Diffraction limited
- Exceptional clarity and contrast

Part #	Mount	Image Diagonal (mm)	Focal Length (mm)	F/# Range	Minimum Operating Distance (mm)	Image Size at MOD		Filter Thread
						Width (mm)	Height (mm)	
1-15838	F/C-mount	42	25	8 (fixed)	45	68	51	none
1-18820	F-mount/M42	43	50	2-22	500	340	250	M 58x0.75
1-17494	—	90	86	4-22	95	72	54	M 55x0.75

25 mm Lens Magnification Specifications

Mag.	Object Size	W.D. (mm)	Spot Size	Image MTF Cut-off	Object MTF Cut-off	Object NA	Image NA	Object Side Depth of Field
0.50X	85	45	6.5 μ	140	70	0.0212	0.0425	1.1
0.34X	127	70	5.6 μ	160	50	0.0159	0.0476	1.9
0.20X	212	120	5.2 μ	190	38	0.0105	0.0526	4.5
0.14X	318	183	4.8 μ	200	25	0.0074	0.0556	9.1
0.10X	424	245	4.8 μ	200	20	0.0057	0.0572	15.4

*Measurements are in millimeters unless otherwise specified.

Zeiss Lenses

Zeiss ZF lenses offer the image quality associated with professional photography for technical and industrial applications. The ZF lenses are compatible with the Nikon F-Bayonet, the globally recognized standard for high-resolution industrial cameras with large format image sensors.

Zeiss ZF lenses feature manual focusing of the highest precision and the robust design. High image definition, color purity, stray light absorption, and excellent distortion correction.



	Part #	Mount	Image Diagonal (mm)	Focal Length (mm)	F/# Range	Minimum Operating Distance (meters)	Image Size at MOD		Filter Thread
							Width (mm)	Height (mm)	
Standard	1-18808	F-mount	43	18	3.5-22	0.30	440	290	M 82x0.75
	1-18809	F-mount	43	21	2.8-22	0.22	190	124	M 82x0.75
	1-18810	F-mount	43	25	2.8-22	0.17	830	550	M 58x0.75
	1-18811	F-mount	43	28	2.0-22	0.24	170	110	M 58x0.75
	1-18812	F-mount	43	35	2.0-22	0.30	190	130	M 58x0.75
	1-18813	F-mount	43	50	1.4-16	0.45	240	160	M 58x0.75
	1-18814	F-mount	43	50	2.0-22	0.24	720	480	M 67x0.75
	1-18815	F-mount	43	85	1.4-16	1.00	360	240	M 72x0.75
	1-18816	F-mount	43	100	2.0-22	0.44	720	480	M 67x0.75

Kowa Lenses

These large format lenses are optimized for machine vision, inspection, quality control, etc. Their rugged, compact design makes them ideal for demanding applications. Low distortion allows them to be used for close distance inspection and correspond to 4K line scan cameras.



	Part #	Mount	Image Diagonal (mm)	Focal Length (mm)	F/# Range	Minimum Operating Distance (meters)	Image Size at MOD		Filter Thread
							Width (mm)	Height (mm)	
Standard	1-19711	F-mount	43.3	28	2.8-16	0.30	388	291	M 72x0.75
	1-19712	F-mount	43.3	35	2.8-16	0.26	210	158	M 52x0.75
	1-19713	F-mount	43.3	50	2.8-16	0.26	135	102	M 52x0.75
3CCD	1-19908	F-mount	30.0	28	2.8-22	0.50	247	185	M 72x0.75
IR	1-19909	F-mount	43.3	50	1.9-16	0.50	269	202	M 52x0.75
4/3"	1-19910	C-mount	23.0	12	2.0-22	0.10	182	136	M 55x0.75
	1-19911	C-mount	23.0	16	2.0-22	0.10	135	101	M 40.5x0.5
	1-19912	C-mount	23.0	25	2.0-16	0.15	125	93	M 40.5x0.5
	1-19913	C-mount	23.0	35	2.0-16	0.20	100	75	M 37.5x0.5
	1-19914	C-mount	23.0	50	2.0-22	0.30	100	75	M 37.5x0.5

Navitar Factory Automation Lenses

Navitar offers quality video lenses from wide angle to telephoto all with high resolution, low distortion and even illumination across the image plane of your camera.

Our large selection of low magnification video lenses includes Fujinon, Kowa, SWIR, Zoom 7000, etc. for industrial applications. Quality construction coupled with precision engineering results in video optics that are sharp, high resolution and optically precise.



4/3" Format Fixed Focal Length Lenses

Model	Megapixel Fixed Focal Length Lenses				
	1-19910	1-19911	1-19912	1-19913	1-19914
Focal Length (mm)	12	16	25	35	50
Iris Range/F-Stop	2.0 - 22	2.0 - 22	2.0 - 16	2.0 - 16	2.0 - 22
Control	Iris	Manual w/ lock screws	Manual w/ lock screws	Manual w/ lock screws	Manual w/ lock screws
	Focus	Manual w/ lock screws	Manual w/ lock screws	Manual w/ lock screws	Manual w/ lock screws
	Zoom	—	—	—	—
Minimum Object Area (mm)	4/3"	182.0 x 136.0	135.0 x 101.0	125.0 x 93.0	100.0 x 75.0
	1"	126.6 x 94.6	93.9 x 70.2	86.9 x 64.7	69.6 x 52.2
	2/3"	87.0 x 65.0	64.5 x 48.3	59.8 x 44.5	47.8 x 35.9
Filter Diameter (mm)	Ø55.0 P=0.75	Ø40.5 P=0.50	Ø40.5 P=0.50	Ø37.5 P=0.50	Ø37.5 P=0.50
Mount	C-Mount	C-Mount	C-Mount	C-Mount	C-Mount
Weight (grams)	270	250	255	210	235

1.1" Format Fixed Focal Length Lenses

Model	NMV-6M1.1	NMV-8M1.1	NMV-12M1.1	NMV-16M1.1	NMV-25M1.1	NMV-35M1.1	NMV-50M1.1
Focal Length (mm)	6.5	8.5	12	16	25	35	50
Iris Range/F-Stop	2.5 - 16	2.5 - 16	1.8 - 16	1.8 - 16	1.8 - 16	1.8 - 16	1.8 - 16
Control	Iris	Manual w/ lock screws	Manual w/ lock screws	Manual w/ lock screws	Manual w/ lock screws	Manual w/ lock screws	Manual w/ lock screws
	Focus	Manual w/ lock screws	Manual w/ lock screws	Manual w/ lock screws	Manual w/ lock screws	Manual w/ lock screws	Manual w/ lock screws
Minimum Object Area (mm)	1.1"	256 x 190	184 x 138	135 x 101	102 x 77	64 x 48	84 x 63
	1"	231 x 172	167 x 125	123 x 92	93 x 70	58 x 44	76 x 57
	2/3"	157 x 117	115 x 86	84 x 63	64 x 48	40 x 30	52 x 39
Focusing Range (m)	0.1 - ∞	0.1 - ∞	0.1 - ∞	0.1 - ∞	0.1 - ∞	0.2 - ∞	0.1 - ∞
Filter Diameter (mm)	Ø82.0 P=0.75	Ø62.0 P=0.75	Ø52.0 P=0.75	Ø35.5 P=0.50	Ø35.5 P=0.50	Ø40.5 P=0.50	Ø40.5 P=0.50
Mount	C-Mount	C-Mount	C-Mount	C-Mount	C-Mount	C-Mount	C-Mount
Weight (grams)	310	230	260	200	220	205	205

Navitar Factory Automation Lenses

1" Format Lenses

		6 Megapixel Fixed Focal Length Lenses				
Model		1-24420	1-24421	1-24422	1-24423	1-24424
Focal Length (mm)		12	16	25	35	50
Iris Range/F-Stop		1.8 - 16	1.8 - 16	1.8 - 16	2.0 - 16	2.0 - 16
Control	Iris	Manual w/ lock screws	Manual w/ lock screws	Manual w/ lock screws	Manual w/ lock screws	Manual w/ lock screws
	Focus	Manual w/ lock screws	Manual w/ lock screws	Manual w/ lock screws	Manual w/ lock screws	Manual w/ lock screws
Minimum Object Area (mm)	1"	125.0 x 93.0	93.5 x 69.9	86.0 x 64.0	70.0 x 52.5	70.0 x 52.5
	2/3"	85.9 x 63.9	64.3 x 48.1	59.1 x 44.0	48.1 x 36.1	48.1 x 36.1
	1/2"	62.5 x 46.5	46.8 x 34.9	43.0 x 32.0	35.0 x 26.3	35.0 x 26.3
Focusing Range (m)		0.10 - ∞	0.10 - ∞	0.15 - ∞	0.20 - ∞	0.30 - ∞
Filter Diameter (mm)		Ø40.5 P=0.50	Ø34.0 P=0.50	Ø34.0 P=0.50	Ø34.0 P=0.50	Ø34.0 P=0.50
Mount		C-Mount	C-Mount	C-Mount	C-Mount	C-Mount
Weight (grams)		252	240	245	200	210

		Megapixel Fixed Focal Length Lenses							
Model		NMV-6M1	NMV-8M1	NMV-12M1	NMV-16M1	NMV-25M1	NMV-35M1	NMV-50M1	NMV-75M1
Focal Length (mm)		6	8	12.5	16	25	35	50	75
Iris Range/F-Stop		1.8-16	1.4-16	1.4-16	1.4-16	1.4-16	1.4-16	1.4-16	1.8-16
Control	Iris	Manual w/ lock screws	Manual w/ lock screws	Manual w/ lock screws	Manual w/ lock screws	Manual w/ lock screws	Manual w/ lock screws	Manual w/ lock screws	Manual w/ screw locks
	Focus	Manual w/ lock screws	Manual w/ lock screws	Manual w/ lock screws	Manual w/ lock screws	Manual w/ lock screws	Manual w/ lock screws	Manual w/ lock screws	Manual w/ lock screws
Minimum Object Area (mm)	1"	267.4 x 196.3	147.0 x 110.5	307.5 x 230.5	227.0 x 170.5	140.8 x 105.6	96.9 x 72.7	115.2 x 86.4	157.9 x 118.4
	2/3"	183.8 x 134.9	101.2 x 75.9	211.2 x 158.4	156.2 x 117.1	96.8 x 72.6	66.6 x 50.0	79.2 x 59.4	108.6 x 81.4
	1/2"	133.7 x 98.1	73.6 x 55.2	153.6 x 115.2	113.6 x 85.2	70.4 x 52.8	48.5 x 36.4	57.6 x 43.1	78.9 x 59.2
Focusing Range (m)		0.1 - ∞	0.1 - ∞	0.3 - ∞	0.3 - ∞	0.3 - ∞	0.3 - ∞	0.5 - ∞	1.0 - ∞
Filter Diameter (mm)		—	Ø55 P=0.75	Ø35.5 P=0.50	Ø35.5 P=0.50	Ø35.5 P=0.50	Ø35.5 P=0.50	Ø40.5 P=0.50	Ø46 P=0.75
Mount		C-Mount	C-Mount	C-Mount	C-Mount	C-Mount	C-Mount	C-Mount	C-Mount
Weight (grams)		215	205	160	150	135	135	210	195

		Fixed Focal Length		High Speed		Zoom	
Model		NMV-2514	NMV-5018	DO-1795	DO-2595	DO-5095	NMV-6X16
Focal Length (mm)		25	50	17	25	50	16 - 100
Iris Range/F-Stop		1.4 - Close	1.8 - Close	0.95 - 16	0.95 - 16	0.95 - 16	1.9 - Close
Control	Iris	Manual	Manual	Manual w/ lock screws	Manual w/ lock screws	Manual w/ lock screws	Manual
	Focus	Manual	Manual	Manual w/ lock screws	Manual w/ lock screws	Manual w/ lock screws	Manual
	Zoom	—	—	—	—	—	Manual
Minimum Object Area (mm)	1"	27 x 21	15 x 11	363 x 272	243 x 182	140 x 105	Wide 81.2 x 60.9 Tele 13.6 x 10.2
	2/3"	—	—	250 x 187	167 x 125	97 x 72	—
	1/2"	—	—	182 x 136	121 x 91	70 x 53	—
Focusing Range (m)		0.5 - ∞	0.7 - ∞	0.3 - ∞	0.5 - ∞	0.6 - ∞	1.1 - ∞
Filter Diameter (mm)		Ø34 P=0.5	Ø40.5 P=0.50	Ø40.5 P=0.50	Ø40.5 P=0.50	Ø62 P=0.75	Ø58 P=0.75
Mount		C-Mount	C-Mount	C-Mount	C-Mount	C-Mount	C-Mount
Weight (grams)		81	145	170	140	490	829

Navitar Factory Automation Lenses

1" Format Ruggedized Megapixel Lenses

Model		Megapixel Fixed Focal Length Lenses					
		1-26382	1-26383	1-26384	1-26385	1-26386	1-26387
Focal Length (mm)		8	12.5	16	25	35	50
Iris Range/F-Stop		1.4	1.4	1.4	1.4	1.4	1.4
Control	Iris	Manual	Manual	Manual	Manual	Manual	Manual
	Focus	Manual	Manual	Manual	Manual	Manual	Manual
Minimum Object Area (mm)	1"	80 x 63	56 x 43	44 x 34	29 x 22	21 x 16	15 x 11
	2/3"	58 x 48	39 x 30	31 x 23	20 x 15	14 x 11	10 x 8
	1/1.8"	49 x 37	32 x 24	25 x 19	17 x 12	17 x 12	8 x 6
Focusing Range (m)		0.1 - ∞	0.3 - ∞	0.3 - ∞	0.3 - ∞	0.3 - ∞	0.5 - ∞
Filter Diameter (mm)		Ø55 P=0.75	Ø35.5 P=0.50	Ø35.5 P=0.50	Ø35.5 P=0.50	Ø35.5 P=0.50	Ø40.58 P=0.505
Mount		C-Mount	C-Mount	C-Mount	C-Mount	C-Mount	C-Mount
Weight (grams)		183	130	120	104	133	170

2/3" Format Fixed Focal Length Lenses

Model		NMV-5M23	NMV-8M23	NMV-12M23	NMV-16M23	NMV-25M23	NMV-35M23	NMV-50M23
Focal Length (mm)		5	8	12	16	25	35	50
Iris Range/F-Stop		2.8 x 16	1.4 - close	1.4 - close	1.4 - 16	1.4 - 16	2.0 - 16	2.8 - 22
Control	Iris	Manual w/ lock screws	Manual w/ lock screws	Manual w/ lock screws	Manual w/ lock screws	Manual w/ lock screws	Manual w/ lock screws	Manual w/ lock screws
	Focus	Manual w/ lock screws	Manual w/ lock screws	Manual w/ lock screws	Manual w/ lock screws	Manual w/ lock screws	Manual w/ lock screws	Manual w/ lock screws
Minimum Object Area (mm)	2/3"	197 x 148	117 x 88	110 x 83	113 x 84	71 x 53	48 x 36	29 x 22
	1/2"	110 x 105	84 x 63	79 x 59	80 x 60	51 x 38	33 x 26	21 x 16
	1/3"	82 x 78	63 x 47	59 x 44	60 x 45	38 x 28	25 x 19	16 x 12
	1/4"	55 x 52	49 x 31	39 x 29	40 x 30	25 x 14	16 x 13	10 x 8
Focusing Range (m)		0.10 - ∞	0.12 - ∞	0.15 - ∞	0.2 - ∞	0.2 - ∞	0.2 - ∞	0.2 - ∞
Filter Diameter (mm)		Ø40.5 P=0.50	Ø27 P=0.50	Ø27 P=0.50	Ø25.5 P=0.50	Ø27.0 P=0.50	Ø27.0 P=0.50	Ø27.0 P=0.50
Mount		C-Mount	C-Mount	C-Mount	C-Mount	C-Mount	C-Mount	C-Mount
Weight (grams)		85	90	85	85	89	70	95

Navitar Factory Automation Lenses

2/3" Format Fixed Focal Length Lenses

Model		NMV-6	NMV-8	NMV-12	NMV-16	NMV-25	NMV-35	NMV-50
Focal Length (mm)		6	8	12	16	25	35	50
Iris Range/F-Stop		1.4 - 16	1.4 - 16	1.4 - 16	1.4 - 16	1.6 - 16	1.6 - 16	2.0 - 22
Control	Iris	Manual w/ lock screws	Manual w/ lock screws	Manual w/ lock screws	Manual w/ lock screws	Manual w/ lock screws	Manual w/ lock screws	Manual w/ lock screws
	Focus	Manual w/ lock screws	Manual w/ lock screws	Manual w/ lock screws	Manual w/ lock screws	Manual w/ lock screws	Manual w/ lock screws	Manual w/ lock screws
Minimum Object Area (mm)	2/3"	367 x 251	260 x 184	237 x 173	112 x 83	119 x 89	127 x 95	85 x 64
	1/2"	264 x 181	187 x 132	170 x 125	80 x 60	86 x 64	91 x 68	61 x 46
	1/3"	198 x 136	140 x 99	127 x 93	60 x 45	64 x 48	68 x 51	46 x 34
	1/4"	132 x 90	93 x 66	85 x 62	40 x 30	43 x 32	45 x 34	30 x 23
Focusing Range (m)		0.1 - ∞	0.1 - ∞	0.1 - ∞	0.2 - ∞	0.2 - ∞	0.35 - ∞	0.5 - ∞
Filter Diameter (mm)			Ø27.0 P=0.50	Ø27.0 P=0.50	Ø27.0 P=0.50	Ø27.0 P=0.50	Ø30.5 P=0.50	Ø30.5 P=0.50
Mount		C-Mount	C-Mount	C-Mount	C-Mount	C-Mount	C-Mount	C-Mount
Weight (grams)		63	60	63	55	58	85	88

10 Megapixel Fixed Focal Length Lenses								
Model	1-19552	1-19553	1-19554	1-19555	1-19556	1-19557	1-19558	
Focal Length (mm)		5.0	8.5	12.0	16.0	25.0	35.0	50.0
Iris Range/F-Stop		1.8-16	1.8-22	1.8-11	1.8-16	1.8-16	2.0-16	2.8-16
Control	Iris	Manual w/ lock screws	Manual w/ lock screws	Manual w/ lock screws	Manual w/ lock screws	Manual w/ lock screws	Manual w/ lock screws	Manual w/ lock screws
	Focus	Manual w/ lock screws	Manual w/ lock screws	Manual w/ lock screws	Manual w/ lock screws	Manual w/ lock screws	Manual w/ lock screws	Manual w/ lock screws
Minimum Object Area (mm)	2/3"	197.0 x 147.0	133.2 x 99.6	80.7 x 60.2	61.1 x 45.7	36.7 x 27.5	23.4 x 17.6	19.1 x 14.3
	1/2"	143.2 x 107.0	96.9 x 72.4	58.7 x 43.8	44.4 x 33.2	26.7 x 20.0	17.0 x 12.8	13.9 x 10.4
	1/3"	107.4 x 80.2	72.7 x 54.3	44.0 x 32.8	33.2 x 24.9	20.0 x 15.0	12.8 x 9.6	10.4 x 7.8
Focusing Range (m)		0.1 - ∞	0.1 - ∞	0.1 - ∞	0.1 - ∞	0.1 - ∞	0.1 - ∞	0.1 - ∞
Filter Diameter (mm)		Ø46.0 P=0.75	Ø34.0 P=0.50	Ø25.5 P=0.50	Ø25.5 P=0.50	Ø25.5 P=0.50	Ø34.0 P=0.50	Ø30.5 P=0.50
Mount		C-Mount	C-Mount	C-Mount	C-Mount	C-Mount	C-Mount	C-Mount
Weight (grams)		120	115	105	90	95	160	170

Navitar Factory Automation Lenses

2/3" Format Fixed Focal Length Lenses

5 Megapixel Fixed Focal Length Lenses				
Model	1-24830	1-24831	1-24832	1-24833
Focal Length (mm)	12.5	16.0	25.0	35.0
Iris Range/F-Stop	1.4-16	1.4-16	1.6-16	1.6-16
Control	Iris	Manual w/ lock screws	Manual w/ lock screws	Manual w/ lock screws
	Focus	Manual w/ lock screws	Manual w/ lock screws	Manual w/ lock screws
Minimum Object Area (mm)	2/3"	81.4 x 60.9	64.6 x 48.4	35.1 x 26.3
	1/2"	59.2 x 44.3	47.0 x 35.2	25.5 x 19.1
	1/3"	44.4 x 33.2	35.2 x 26.4	19.1 x 14.3
Focusing Range (m)	0.1 - ∞	0.1 - ∞	0.1 - ∞	0.18 - ∞
Filter Diameter (mm)	Ø30.5 P=0.50	Ø30.5 P=0.50	Ø30.5 P=0.50	Ø30.5 P=0.50
Mount	C-Mount	C-Mount	C-Mount	C-Mount
Weight (grams)	130	125	115	120

Model	NMV-75	NMV-100	NAV-1614	NAV-2514	NAV-3520	NAV-5028
Focal Length (mm)	75	100	16	25	35	50
Iris Range/F-Stop	2.5 - 22	2.8 - 32	1.4 - 16	1.4 - 22	2.0 - 22	2.8 - 22
Control	Iris	Manual w/lock screws	Manual w/lock screws	Manual w/lock screws	Manual w/lock screws	Manual w/lock screws
	Focus	Manual w/lock screws	Manual w/lock screws	Manual w/lock screws	Manual w/lock screws	Manual w/lock screws
Minimum Object Area (mm)	2/3"	51 x 38	37 x 27	119 x 89	72 x 54	46 x 34
	1/2"	37 x 27	27 x 20	87 x 65	52 x 39	33 x 25
	1/3"	28 x 20	20 x 15	65 x 49	39 x 29	25 x 19
	1/4"	18 x 13	13 x 10	43 x 32	26 x 19	17 x 13
Focusing Range (m)	1.2 - ∞	2.0 - ∞	0.25 - ∞	0.25 - ∞	0.25 - ∞	0.5 - ∞
Filter Diameter (mm)	Ø34.0 P=0.50	Ø40.5 P=0.50	Ø25.5 P=0.50	Ø25.5 P=0.50	Ø25.5 P=0.50	Ø25.5 P=0.50
Mount	C-Mount	C-Mount	C-Mount	C-Mount	C-Mount	C-Mount
Weight (grams)	100	140	42	45	55	55

Navitar Factory Automation Lenses

2/3" Format Lenses

Model	Telecentric, Fixed Focal Length	Zoom	
	TC-5028	NMV-6X11.5	Zoom 7000
Focal Length (mm)	50	11.5 - 69	18 - 108 (6x) (Close-up Focusing)
Iris Range/F-Stop	2.8 - Close	1.4 - Close	2.5 - Close
Control	Iris	Manual	Manual
	Focus	Manual	Manual
	Zoom	—	Manual
Minimum Object Area (mm)	2/3"	8.1 x 6.1	Wide 252 x 195 Tele 43 x 33
	1/2"	5.9 x 4.4	Wide 183 x 142 Tele 31 x 24
	1/3"	3.8 x 3.3	Wide 138 x 106 Tele 23 x 18
	1/4"	2.9 x 2.2	Wide 91 x 71 Tele 15 x 12
Focusing Range (m)	0.5 - ∞ *	1.0 - ∞	0.13 - ∞
Filter Diameter (mm)	Ø37 P=0.75	Ø46 P=0.75	Ø52 P=0.75
Mount	C-Mount	C-Mount	C-Mount
Weight (grams)	318	410	595

*Focusing range in non-telecentric mode.

2/3" Format Ruggedized Megapixel Lenses

Model	Megapixel Fixed Focal Length Lenses					
	1-25551	1-25552	1-25553	1-25554	1-25555	1-25556
Focal Length (mm)	8	12	16	25	35	50
Iris Range/F-Stop	1.4 - 16	1.4 - 16	1.4 - 16	1.6 - 16	1.6 - 16	2.0 - 20
Control	Iris	Manual	Manual	Manual	Manual	Manual
	Focus	Manual	Manual	Manual	Manual	Manual
Minimum Object Area (mm)	2/3"	64.2 x 47.7	42.5 x 31.7	30.5 x 22.8	21.0 x 15.7	14.4 x 10.8
	1/1.8"	52.4 x 39.1	34.6 x 25.9	23.8 x 18.7	17.2 x 12.9	11.8 x 8.8
	1/2"	46.2 x 34.67	30.7 x 23.0	22.2 x 16.6	15.3 x 11.4	10.5 x 7.9
Focusing Range (m)	0.1 - ∞	0.1 - ∞	0.2 - ∞	0.2 - ∞	0.3 - ∞	0.5 - ∞
Filter Diameter (mm)	Ø27 P=0.50	Ø27 P=0.50	Ø27 P=0.50	Ø27 P=0.50	Ø30.5 P=0.50	Ø30.5 P=0.50
Mount	C-Mount	C-Mount	C-Mount	C-Mount	C-Mount	C-Mount
Weight (grams)	60	63	55	55	85	90

Navitar Factory Automation Lenses

1/2" Format Lenses

Model	Wide Angle Fixed Focal Length				Fixed Focal Length		Zoom
	NMV-4WA	NMV-5WA	NMV-6WA	NMV-12WA	NAV-614	NMV-1214	NMV-6X8
Focal Length (mm)	3.5	4.5	6	12	6	12	8-48
Iris Range/F-Stop	1.4 - 16	1.4 - 16	1.4 - 16	2.8 - 32	1.4 - 16	1.4 - Close	1.0 - Close
Control	Iris	Manual w/lock Screws	Manual w/lock Screws	Manual w/lock Screws	Manual w/lock Screws	Manual w/lock Screws	Manual w/lock Screws
	Focus	Manual w/lock Screws	Manual w/lock Screws	Manual w/lock Screws	Manual w/lock Screws	Manual w/lock Screws	Manual w/lock Screws
	Zoom	—	—	—	—	—	Manual
Minimum Object Area (mm)	1/2"	396 x 247	260 x 180	174 x 128	167 x 123	176 x 130	17 x 13
	1/3"	297 x 185	195 x 135	130 x 96	125 x 92	132 x 97	—
	1/4"	198 x 123	130 x 90	87 x 64	83 x 61	88 x 65	—
Focusing Range (m)	0.2 - ∞	0.2 - ∞	0.2 - ∞	0.3 - ∞	0.1 - ∞	0.3 - ∞	1.0 - ∞
Filter Diameter (mm)	—	—	Ø25.5 P=0.50	Ø25.5 P=0.50	Ø30.5 P=0.75	Ø30.5 P=0.50	Ø46 P=0.75
Mount	C-Mount	C-Mount	C-Mount	C-Mount	C-Mount	C-Mount	C-Mount
Weight (grams)	60	55	60	56	50	90	395

1/3" Format Lenses

Model	Fixed Focal Length	Zoom
	DO-2814	ZOOM 7010
Focal Length (mm)	2.8	8.5 - 90
Iris Range/F-Stop	1.4 - Close	2.5 - Close
Control	Iris	Manual
	Focus	Manual
	Zoom	—
Minimum Object Area (mm)	1/3"	579 x 414
	1/4"	386 x 276
Focusing Range (m)	0.3 Fixed	Wide 170 x 127.8 Tele 16.8 x 12.6 (w/o close-up lens)
Filter Diameter (mm)	No Filter Thread	Wide 113 x 85 Tele 11 x 8 (w/o close-up lens)
Mount	CS-Mount	C-Mount
Weight (grams)	60	437



Fujinon Factory Automation Lenses

1" Format Fixed Focal Length Lenses

Model	CF12.5HA-1	CF16HA-1	CF25HA-1	CF35HA-1	CF50HA-1	CF75HA-1
Focal Length (mm)	12.5	16	25	35	50	75
Iris Range/F-Stop	1.4 - 22	1.4 - 22	1.4 - 22	1.4 - 22	1.8 - 22	1.8 - 22
Control	Iris	Manual	Manual	Manual	Manual	Manual
	Focus	Manual	Manual	Manual	Manual	Manual
Minimum Object Area (mm)	1"	120 x 90	100 x 75	65 x 48	73 x 55	76 x 57
	1/2"	—	—	—	—	—
Focusing Range (m)	0.1 - ∞	0.1 - ∞	0.1 - ∞	0.2 - ∞	0.4 - ∞	0.9 - ∞
Filter Diameter (mm)	Ø49 P=0.75	Ø49 P=0.75	Ø49 P=0.75	Ø49 P=0.75	Ø49 P=0.75	Ø49 P=0.75
Mount	C-Mount	C-Mount	C-Mount	C-Mount	C-Mount	C-Mount
Weight (grams)	280	280	300	190	200	300

Fujinon Factory Automation Lenses

2/3" Format Fixed Focal Length Lenses

Model		HF12.5SA-1	HF16SA-1	HF25SA-1	HF35SA-1	HF50SA-1	HF75SA-1
Focal Length (mm)		12.5	16	25	35	50	75
Iris Range/F-Stop		F1.4 - F22	F1.4 - F22	F1.4 - F22	F1.4 - F22	F1.8 - F22	F1.8 - F22
Control	Iris	Manual	Manual	Manual	Manual	Manual	Manual
	Focus	Manual	Manual	Manual	Manual	Manual	Manual
Minimum Object Area (mm)	2/3"	83 x 62	69 x 51	44 x 33	50 x 38	70 x 52	101 x 76
	1/2"	60 x 45	50 x 37	32 x 24	37 x 27	51 x 38	74 x 55
	1/3"	45 x 34	37 x 28	24 x 18	27 x 21	38 x 28	55 x 41
	1/4"	—	—	—	—	—	—
Focusing Range (m)		0.1 - ∞	0.1 - ∞	0.1 - ∞	0.2 - ∞	0.2 - ∞ *	0.9 - ∞ **
Filter Diameter (mm)		Ø49 P=0.75	Ø49 P=0.75	Ø49 P=0.75	Ø49 P=0.75	Ø49 P=0.75	Ø49 P=0.75
Mount		C-Mount	C-Mount	C-Mount	C-Mount	C-Mount	C-Mount
Weight (grams)		295	285	315	185	240	300

Model		HF8XA-1	HF12XA-1	HF16XA-1	HF25XA-1	HF35XA-1
Focal Length (mm)		8	12	16	25	35
Iris Range/F-Stop		F1.6 - F16	F1.6 - F16	F1.6 - F16	F1.6 - F16	F1.9 - F16
Control	Iris	Manual	Manual	Manual	Manual	Manual
	Focus	Manual	Manual	Manual	Manual	Manual
Minimum Object Area (mm)	2/3"	106 x 80	71 x 53	55 x 42	35 x 26	50 x 38
	1/2"	77 x 58	52 x 39	40 x 30	26 x 19	36 x 27
	1/3"	58 x 43	39 x 29	30 x 23	19 x 14	27 x 20
Focusing Range (m)		0.1 - ∞	0.1 - ∞	0.1 - ∞	0.1 - ∞	0.2 - ∞
Filter Diameter (mm)		Ø25.5 P=0.50	Ø25.5 P=0.50	Ø25.5 P=0.50	Ø25.5 P=0.50	Ø25.5 P=0.50
Mount		C-Mount	C-Mount	C-Mount	C-Mount	C-Mount
Weight (grams)		79	79	71	72	60

Model		HF9HA-1S	HF12.5HA-1S	HF16HA-1S	HF25HA-1S	HF35HA-1S	HF50HA-1S	HF75HA-1S
Focal Length (mm)		9	12.5	16	25	35	50	75
Iris Range/F-Stop		1.4 - 16	1.4 - 16	1.4 - 16	1.4 - 16	1.6 - 22	2.3 - 22	2.8 - 22
Control	Iris	Manual	Manual	Manual	Manual	Manual	Manual	Manual
	Focus	Manual	Manual	Manual	Manual	Manual	Manual	Manual
Minimum Object Area (mm)	2/3"	108 x 81	78 x 58	63 x 47	53 x 40	59 x 44	77 x 57	114 x 85
	1/2"	79 x 59	57 x 42	46 x 34	38 x 29	43 x 32	56 x 42	83 x 62
	1/3"	59 x 44	42 x 32	34 x 26	29 x 22	32 x 24	42 x 31	62 x 47
	1/4"	44 x 33	32 x 24	26 x 19	22 x 16	24 x 18	31 x 24	47 x 35
Focusing Range (m)		0.1 - ∞	0.1 - ∞	0.1 - ∞	0.15 - ∞	0.25 - ∞ *	0.5 - ∞	1.1 - ∞
Filter Diameter (mm)		Ø27 P=0.50	Ø25.5 P=0.50	Ø25.5 P=0.50	Ø25.5 P=0.50	Ø25.5 P=0.50	Ø25.5 P=0.50	Ø30.5 P=0.50
Mount		C-Mount	C-Mount	C-Mount	C-Mount	C-Mount	C-Mount	C-Mount
Weight (grams)		55	45	45	45	45	45	55

NOTES:

All Fujinon "HF" lenses come with focus and iris locking screws.

* Using an extension tube longer than 5mm will increase the M.O.D. to 0.3m.

** Using an extension tube longer than 5mm will increase the M.O.D. to 0.5m.

1/2" Format Lenses

Model		Fixed Focal Length
Model		DF6HA-1S*
Focal Length (mm)		6
Iris Range/F-Stop		1.2 - 16
Control	Iris	Manual
	Focus	Manual
Minimum Object Area (mm)	1"	—
	2/3"	—
	1/2"	122 x 92
	1/3"	92 x 69
	1/4"	69 x 52
Focusing Range (m)		0.1 - ∞
Filter Diameter (mm)		Ø27 P=0.5
Mount		C-Mount
Weight (grams)		45

*Locking screws on focus and iris are standard.

1/3" Format Lenses for 3CCD Cameras

Model		Fixed Focal Length		
Model		TF2.8DA-8	TF4DA-8	TF15DA-8
Focal Length (mm)		2.8	4	15
Iris Range/F-Stop		2.2 - Close	2.2 - Close	2.2 - Close
Control	Iris	Manual	Manual	Manual
	Focus	Manual	Manual	Manual
Minimum Object Area (mm)	1"	—	—	—
	2/3"	—	—	—
	1/2"	—	—	—
	1/3"	218 x 153	131 x 98	36 x 27
	1/4"	145 x 102	87 x 65	24 x 18
Focusing Range (m)		0.1 - ∞	0.1 - ∞	0.1 - ∞
Filter Diameter (mm)		No Filter Thread	Ø27 P=0.5	Ø25.5 P=0.5
Mount		C-Mount	C-Mount	C-Mount
Weight (grams)		75	70	60

SWIR / Hyperspectral Lenses

Navitar's fixed focal length SWIR/Hyperspectral lenses are specifically designed for SWIR (short wave infrared) cameras and applications. Lenses are available from 8mm to 50mm focal lengths. These lenses are ideal for a variety of imaging applications where SWIR cameras are employed such as perimeter surveillance, food sorting, toll-way monitoring, border and port security, quality control or aerial imaging.



Model		Fixed Focal Length					
Model		SWIR-8	SWIR-12	SWIR-16	SWIR-25	SWIR-35	SWIR-50
Focal Length (mm)		8	12.5	16	25	35	50
Iris Range/F-Stop		1.4 - 16	1.4 - 16	1.4 - 16	1.4 - 16	1.4 - 16	1.4 - 16
Control	Iris	Manual	Manual	Manual	Manual	Manual	Manual
	Focus	Manual	Manual	Manual	Manual	Manual	Manual
Minimum Object Area (mm)	Zoom	—	—	—	—	—	—
	1"	147.0 x 110.5	307.5 x 230.5	227.0 x 170.5	192.0 x 144.0	133.5 x 100.1	140.8 x 105.6
	2/3"	101.2 x 75.9	211.2 x 158.4	156.2 x 117.1	132.0 x 99.0	91.8 x 68.8	96.8 x 72.6
Focusing Range (m)	1/2"	73.6 x 55.2	153.6 x 115.2	113.6 x 85.2	96.0 x 72.0	66.7 x 50.0	70.4 x 52.8
		0.1 - ∞	0.3 - ∞	0.3 - ∞	0.3 - ∞	0.3 - ∞	0.5 - ∞
Filter Diameter (mm)		Ø55 P=0.75	Ø35.5 P=0.5	Ø35.5 P=0.5	Ø35.5 P=0.5	Ø35.5 P=0.5	Ø40.5 P=0.5
Mount		C-Mount	C-Mount	C-Mount	C-Mount	C-Mount	C-Mount
Weight (grams)		205	160	150	135	135	210

Custom SWIR Lens Design Experience

Navitar offers custom-designed SWIR solutions and welcomes your project request. We have designed and built several custom lenses, including a system that detects visible near infrared (NIR) and short wave infrared (SWIR) wavelengths (500 - 1600 nm). The custom design was a F/1.35, 25 mm, C-mount lens.

Please contact your account manager for a custom SWIR quote today.

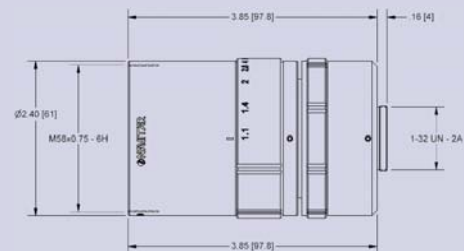

Video Lens Accessories

Extenders (for use with all lenses except SWIR)

A range extender, installed between the lens and camera, will extend the focal length and increase the effective aperture (F/number) of a video lens. For example, using the 2XE range extender will extend the focal length by two times (2X) and double the effective aperture of the following lens: (2X) 50 mm, F/1.3 lens = 100 mm F/2.6

Extention Tube Kit

We also offer an extension tube kit, which allows you to turn standard fixed focal length lenses into macro lenses. The tube(s) mount between the camera and the lens, making it possible for you to focus a C-mount lens at a much closer distance.

Available Accessories

Model	Description
HE15-1	1.5 X Extender, 13.08 mm long, Ø45
HE20-1	2.0X Extender, 13.74 mm long, Ø45
2XE	2.0X Extender, 11.12 mm long, Ø31.92
NMV-EXT	Extension Tube Kit, 5 pieces, 36.5mm total (0.5 mm, 1 mm, 5 mm, 10 mm, 20 mm)
3-6073	5 mm Extension Tube

Converter Lens for Block Cameras

Navitar Converter Lenses

Block cameras have long been used for numerous security, surveillance and industrial applications. Until recently, however, there were very few high quality converter lenses either to improve long-distance viewing or increase magnification.

Ideal for use in Unmanned Aerial Vehicles (UAVs), border security, and industrial automation, Navitar's converter lenses are compact and lightweight, and offer higher quality and a greater range of magnifications than those currently on the market.

Technical Information

Navitar's converter lenses easily interface with block cameras to provide optimal zoom ranges. Relative illumination ranges from 50% to 88%. Part numbers and descriptions may be found below. For outline drawings and specifications detailing optical performance and FOV changes, visit navitar.com

Part Number	Description
1-19271	2X Teleconverter Lens

Mounting Options

Navitar recognizes that each customer's application is unique. Our design team will work closely with each user to develop the best mounting option for your specific project.

Camera Testing

Navitar has tested several cameras with the converter lenses, including Sony's FCB-980S, FCB-EX1000, FCB-H10, FCB-H11, and FCB-EX1020.

Because of the vast number of camera product offerings available we will arrange for a lens to be sent to your company for testing.

Designs exist for magnifications ranging from 4X to 0.4X. Please call for more information.

12X Telecentric Zoom System

The 12X Telecentric Zoom system allows users to reach a true telecentric condition to within less than 0.4° while maintaining constant perspective and magnification. This means that even if the object is slightly out of focus, the size of the image will not change. The 12X Telecentric Zoom provides field coverage from 50 mm down to 4 mm and the coaxial illumination allows clear viewing, even when working with mirror-like surfaces. Also available without coaxial illumination.



Wide Magnification Range and Ultra Long Working Distance

When combined with the 1-50993 12X zoom the telecentric attachments will have a nominal working distance of 173mm +/- 2mm. The working distance can be modified by the factory from 165 to 186mm. Magnifications range from 0.16X to 1.94X with the 1X adapter, and 0.32X to 3.88X with the 2X adapter. Maximum field of view is 50 mm. An upper 2X F-mount adapter may be used to couple an F-Mount camera.

12X Telecentric Zoom Lens Specifications

Mag.	Telecentricity (degrees)			Object NA	Image NA	Object Depth of Focus (mm)	Telecentric Error (mm)			Object Size			Approx. MTF (lp/mm)	Resolvable Features (microns)
	1/4"	1/3"	1/2"				1/4"	1/3"	1/2"	1/4"	1/3"	1/2"		
0.16	0.05	0.06	-0.03	0.005	0.032	19.4	0.018	0.020	-0.009	25.0	37.3	49.7	15	66
0.23	-0.10	-0.09	-0.18	0.007	0.031	9.7	-0.017	-0.016	-0.030	17.4	26.1	34.8	22	46
0.33	-0.19	-0.18	-0.27	0.010	0.030	5.2	-0.016	-0.016	-0.024	12.1	18.2	24.3	30	34
0.47	-0.23	-0.23	-0.31	0.013	0.028	3.0	-0.012	-0.012	-0.016	8.5	12.8	17.0	39	26
0.67	-0.25	-0.25	-0.34	0.016	0.024	1.9	-0.008	-0.008	-0.011	5.9	8.9	11.9	49	21
0.96	-0.27	-0.27	-0.36	0.020	0.021	1.3	-0.006	-0.006	-0.008	4.2	6.3	8.4	59	17
1.36	-0.29	-0.29	-0.38	0.024	0.017	0.9	-0.004	-0.005	-0.006	2.9	4.4	5.9	71	14
1.94	-0.25	-0.24	-0.29	0.028	0.015	0.6	-0.003	-0.003	-0.003	2.1	3.1	4.1	84	12

Video Telecentric

TC-5028

The Navitar TC-5028 telecentric lens is a 50 mm F/2.8 telecentric lens which reduces or eliminates viewing angle error and magnification error while providing high resolution and contrast with low distortion. This compact, lightweight lens can be used with 1/3", 1/2" and 2/3" format cameras and is usable from 0.5X to 1.0X, 1:1.

Specifications for Telecentric Use	
Magnifications	0.5 1.0X
Distortion at 0.5X	-0.3%
Distortion at 1.0X	Less than - 0.1%
Distance from Front Lens to Object	0.5X:115mm 1.0X:85mm

TC-5028 Video Lens Specifications		
Focal Length	50 mm	
Iris Range/ F-Stop	2.8 - Close	
Control	Iris	Manual
	Focus	Manual
	Zoom	N/A
Object Area at M.O.D (HxV)	2/3"	8.1 x 6.1
	1/2"	5.9 x 4.4
	1/3"	3.8 x 3.3
	1/4"	2.9 x 2.2
Focusing Range (meters)	0.5 - infinity	
Field Angle (HxV)	2/3"	10° 03' x 7° 33'
	1/2"	7° 19' x 5° 29'
	1/3"	5° 29' x 4° 07'
	1/4"	3° 39' x 2° 45'
Back Focal Length (mm)	32.5	
Filter Diameter	Ø37 P=0.75	
Mount	C-mount	
Weight (grams)	318	
Exit Pupil Position	48.1(from image plane)	
Vignetting	97%	
Filter Size	M37.5 x 0.5	

Our Projection Expertise

Navitar has designed and produced world-class projection lenses since 1978. We offer a wide range of replacement, conversion, fisheye, and custom projection lenses for projectors up to 4K resolution.

Our projection lenses are ideal for corporate and education facilities, planetariums, museums, simulation, immersive environments, and amusement attractions.



HemiStar® Fisheye Projection Lenses and Custom 4K Designs

Navitar's HemiStar lenses are ideal for small, medium and large planetariums, as well as simulation and immersive projection.

Our fisheye projection lenses have an almost infinite depth of focus, allowing them to maintain sharpness in a variety of settings. We offer both single and multi-projector solutions for 2K and 4K resolution.

Our designs are engineered for peak power and continual thermal cycles through on/off routines. Lenses work with traditional Xenon based light engines up to 40K ANSI lumens as well as 6P platforms up to 60K ANSI.

Our projection expertise includes:

- Relay and Non-Relay Designs
- Rectilinear and Fisheye Designs
- Fisheye Lenses and F-theta Distortion
- Uniform Pixel Mapping at Image Edge
- Unique Chip Sets, Color Off-Sets
- Panel Size Variations in Light Engines
- Customer Masking Requirements
- Tolerance and Sensitivity Analyses

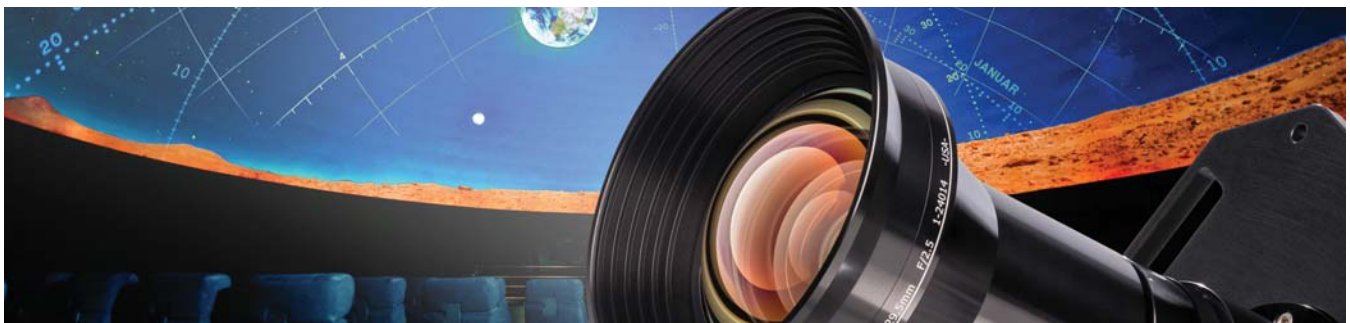

NuView® Replacement Lenses

NuView lenses replace the existing prime lens of your projector and allow you to use your projector in a variety of applications. NuView lenses are compatible with LCD, DLP, DILA and LCOS projectors.

Use a long throw lens to increase projection distance and move your projector farther from the screen.

Use a wide angle lens in rear screen applications or to produce much larger images for front projection.

The zoom feature allows you to choose your projection distance and image size by simply rotating the lens.



ScreenStar® Conversion Lenses

Navitar's ScreenStar conversion lenses are placed in front of your projector's standard lens to change image size or throw distance. These lenses decrease the overall cost of installation by allowing you to reduce the number of projectors being used, or by selecting a lower cost, less featured projector.

ScreenStar lenses work with LCD, DLP, DILA and LCOS projectors.

Imaging and Microscopy Cameras

We offer a wide variety of high-performance CMOS and CCD cameras for your most demanding industrial and microscopy applications.

- Available in 1 MP to 20 MP resolutions
- Fast frame rates
- High resolution, low noise images
- Board level and enclosed models
- Software Development Kit
- Pixelink Capture software
- Customization for OEM
- Autofocus feature available



Machine Vision Camera Models



Model	Color Space	Sensor	Resolution	Lens Format	Sensor Diagonal	Pixel Pitch (μm)	F/R (fps)	Shutter Type	Bit Depth
PL-D7512	M/C	Sony IMX253	12 MP	1.1"	17.6 mm	3.45	33	Global	12
PL-D7912	M/C	Sony IMX304	12 MP	1.1"	17.6 mm	3.45	23	Global	12
PL-D757 (HDR)	M/C	Sony IMX420	7 MP	1.1"	17.6 mm	4.5	57	Global	12
PL-D797	M/C	Sony IMX428	7 MP	1.1"	17.6 mm	4.5	27	Global	12
PL-D7620	M/C	Sony IMX183	20 MP	1"	15.9 mm	2.4	20	Rolling	12
PL-D759	M/C	Sony IMX255	9 MP	1"	16.1 mm	3.45	45	Global	12
PL-D799	M/C	Sony IMX267	9 MP	1"	16.1 mm	3.45	32	Global	12
PL-D725	M/C	ON Semi Vita 5000	5 MP	1"	15.9 mm	4.8	75	Global	10
PL-D726	M	ON Semi IBIS 4	7 MP	1"	13.0 mm	3.5	5	Rolling	10
PL-D734	M/C/NIR	CMOSIS CMV 4000	4 MP	1"	15.9 mm	5.5	90	Global	10
PL-D752	M/C	Sony IMX174	2 MP	1/1.2"	13.4 mm	5.86	167	Global	12
PL-D729	M	ON Semi Mano 9600	9 MP	2/3"	11.0 mm	2.4	22	Rolling	10
PL-D755MU-POL	M	Sony IMX250MZR	5 MP	2/3"	11.1 mm	3.45	36	Global	12
PL-D755	M/C	Sony IMX250	5 MP	2/3"	11.1 mm	3.45	80	Global	12
PL-D795	M/C	Sony IMX264	5 MP	2/3"	11.1 mm	3.45	36	Global	12
PL-D753 (HDR)	M/C	Sony IMX421	3 MP	2/3"	11.0 mm	4.5	141	Global	12
PL-D732	M/C/NIR	CMOSIS cmv2000	2 MP	2/3"	12.7 mm	5.5	170	Global	10
PL-D722	M/C/NIR	ON Semi Vita 2000	2 MP	2/3"	10.9 mm	4.8	87	Global	10
PL-D721P	M	ON Semi Python 1300	1 MP	1/2"	7.9 mm	4.8	212	Global	10
PL-D721	M/C	ON Semi Vita 1300	1 MP	1/2"	7.9 mm	4.8	151	Global	10
PL-D7715	M	ON Semi MT9F002	15 MP	1/2.2"	7.9 mm	1.4	13	Rolling	12
PL-D775	M/C	ON Semi Mono MT9P031 ON Semi Color MT9P006	5 MP	1/2.5"	7.1 mm	2.2	14	Rolling	12

Microscopy Camera Models



Model	Color Space	Sensor	Resolution	Dynamic Range	Lens Format	Sensor Diagonal	Pixel Pitch (µm)	F/R (fps)	Shutter Type	Bit Depth
M12	M/C	Sony IMX253	12 MP (4096 x 3000)	70 dB	1.1"	17.6 mm	3.45	35	Global	12
M12B	M/C	Sony IMX304	12 MP (4096 x 3000)	70 dB	1.1"	17.6 mm	3.45	23	Global	12
M20	M/C	Sony IMX183	20 MP (5472 x 3648)	73 dB	1"	15.9 mm	2.4	20	Rolling	12
M9	M/C	Sony IMX255	9 MP (4096 x 2160)	70 dB	1"	16.1 mm	3.45	48	Global	12
M4	M/C	CMOSIS CMV 4000	4 MP (2048 x 2048)	60 dB	1"	15.9 mm	5.5	90	Global	10
M5	M/C	ON Semi Vita 5000	5 MP (2592 x 2048)	53 dB	1"	15.9 mm	4.8	76	Global	10
M5D	M/C	Sony IMX250	5 MP (2448 x 2048)	70 dB	2/3"	11.1 mm	3.45	81	Global	12
M2	M/C	CMOSIS CMV 2000	2 MP (2048 x 1088)	60 dB	2/3"	12.7 mm	4.8	170	Global	10
M1	M/C	ON Semi Vita 1300	1 MP (1280 x 1024)	53 dB	1/2"	7.9 mm	4.8	151	Global	10
M15	C	ON Semi MT9F002	15 MP (4608 x 3288)	60 dB	1/2.3"	7.9 mm	1.4	13	Rolling	8 or 12

HDR Imaging Cameras

PL-D757 & PL-D753

HDR imaging is a technique used to render a captured image with a greater dynamic range of luminosity than is possible with standard digital imaging. A key feature of the 3rd generation Sony Pregius CMOS sensors is a Dual ADC mode where each pixel can be read out with two different gains.

Typical Applications

- High Security Inspection
- Security
- Real-Time Sports Analysis
- Medical Imaging

Seamless Integration

The Resolv4K, 12X Zoom and Zoom 6000 lens systems seamlessly integrate with Pixelink CMOS cameras giving you high-resolution, low-noise digital imaging solutions backed by industry leading sales and technical support.

Contact your Account Representative for more information.

Software Development Kit

Providing full control of all camera functions, the Pixelink SDK is the software package of choice for developers and system integrators.

Features

- Fast and easy integration
- Free technical support
- Powerful, easy to use interface
- Full U3V compliance on all USB 3.0 cameras
- Get started with a free 30-day trial
- Microsoft Windows and Linux supported
- Supports C/C++, .NET, Visual Studio 2003 and up, Python
- Robust API allowing full control of all camera features
- Driver: USB3 Vision, GigE, 1394/IIDC (DCAM), Direct Show, TWAIN, USB 2.0
- 3rd Party Compatibility: LabVIEW, MATLAB, Halcon, Norpax, Matrox, USB3 Vision, WinRoof



How to Determine the Focal Length Required

To choose the proper lens for an application consider the following:

- Field of View (FOV) - The size of the area to be imaged.
- Working Distance (WD) - Distance from the camera lens to the object or area under surveillance.
- CCD - The size of the camera's image sensor device.

Be consistent. If you are measuring the width of your object, use the horizontal CCD specifications, etc. If you are working in inches, do your calculations in inches and convert to millimeters at the end.

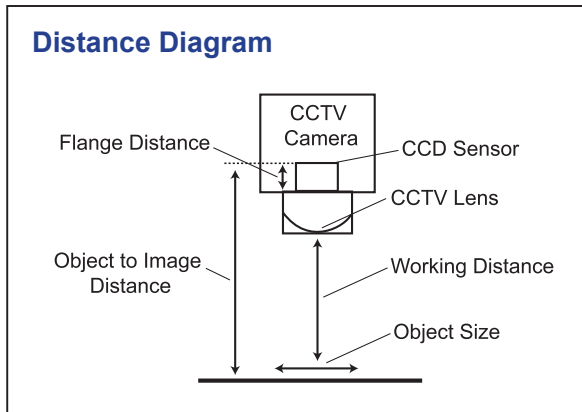

Understanding Focal Length

Video lenses are classified into three categories according to focal length: standard, wide angle and telephoto. Focal length is the distance between the camera sensor and the center of the lens. The greater the focal length, the larger the image will appear. Therefore, the greater the focal length, the more the lens becomes telephoto in application.

- **Standard Lens** - size of the object being viewed is unchanged.
- **Wide Angle Lens** - provides a wider field of view and therefore a smaller image of the object being viewed
- **Telephoto Lens** - produces a larger image of a distant object. The longer the focal length, the larger the object will appear.

$$FL = \frac{CCD \times WD}{FOV}$$

Example: You have a 1/3" C-mount CCD camera (4.8 mm horizontal). There is a 12" (305 mm) distance between the object and the front of the lens. The field of view, or object size, is 2.5" (64 mm). The conversion factor is 1" = 25.4 mm (round up).

Calculation in mm:

FL = 4.8 mm x 305 mm / 64 mm
 FL = 1464 mm / 64 mm
 FL = 23 mm Lens Required

Calculation in inches:

FL = 0.19" x 12" / 2.5"
 FL = 2.28" / 2.5"
 FL = 0.912" x 25.4 mm/inch
 FL = 23 mm Lens Required

Understanding F/#

The f/number is an indication of the brightness of the lens. It is the measurement of the ratio between the focal length and the diameter of the entrance pupil (where the light enters the lens). It determines the amount of light reaching the camera sensor. The smaller the value, the larger the opening and the brighter the image produced by the lens.

Image Size

A lens produces images in the form of a circle, called the image circle. In a video camera, the imaging element has a rectangular sensor area (the image size) that detects the image produced within the image circle. The ratio of the length of the horizontal to vertical sides of a video image is called the aspect ratio, which is normally 4:3 (H:V) for a standard video camera.

Image Size Chart

Image Sensor	Image Circle	Horizontal	Vertical
1/3"	Ø6.0 mm	4.8 mm	3.6 mm
1/2"	Ø8.0 mm	6.4 mm	4.8 mm
2/3"	Ø11.0 mm	8.8 mm	6.6 mm
1"	Ø16.0 mm	12.8 mm	9.6 mm
4/3"	Ø22.5 mm	17.3 mm	13.0 mm
35mm	Ø43.0 mm	36.0 mm	24.0 mm

Image Sensor Size (units in mm)

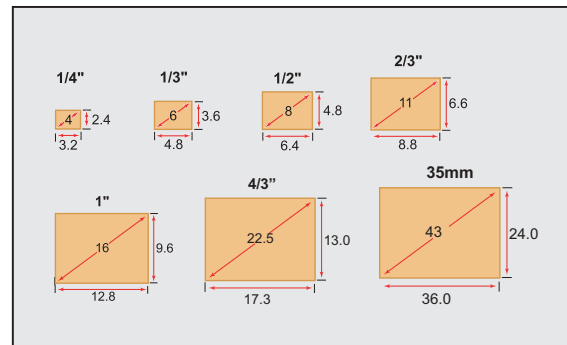
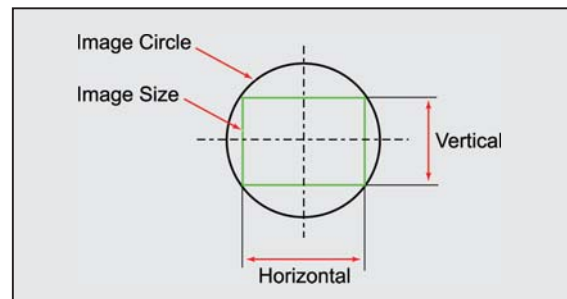

Image Size



Minimum Object Distance

Minimum object distance (M.O.D.) indicates how close the lens can be placed to the object for shooting. It is measured from the vertex of the front glass of the lens.

Angle of View and Field of View

The angle of view is the shooting range that can be viewed by the lens given a specified image size. Normally the angle of view is measured assuming a lens is focused at infinity. The angle of view can be calculated if the focal length and image size are known. If the distance of the object is finite, the angle is not used. Instead, the dimension of the range that can actually be shot, or the field of view, is used.

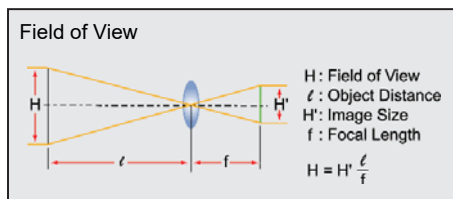
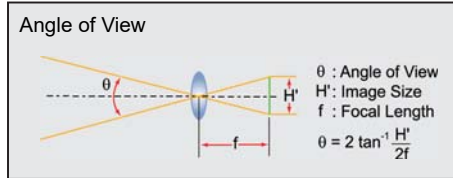

Focal Length

Distance between the principle point in the optical system and the focal point. For a single thin lens, the focal length is equal to the distance between the center of the lens and the focal point.

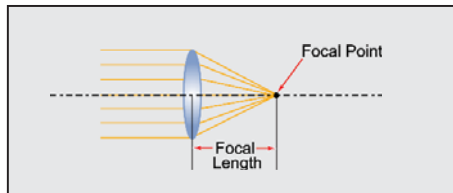

Back Focal Length

Distance between vertex of the rear element lens and image sensor.

Flange Distance

Distance between mechanical mount surface and image sensor (in air).

C-Mount=17.526 mm / .690"

CS-Mount=12.526 mm / .493"

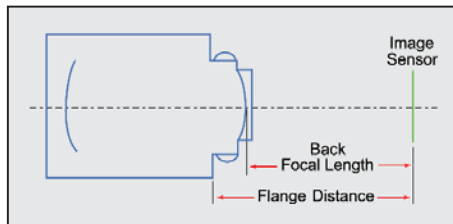

Relationship Between Angle of View and Image Sensor Size

Cameras with different image sensor chip sizes (such as 1/3", 1/2", 2/3", 1" and 4/3"), using the same focal length lens, will each yield a different field of view.

Lenses designed for a larger image sensor device will work on a new, smaller size camera. However, if a lens designed for a smaller format image sensor device (i.e. 1/3") is placed on a larger one (i.e. 2/3"), the image on the monitor will have dark corners. Image sensor sizes are in a ratio of 1:0.69:0.5:0.38:0.25. This means that a 1/2" format is 50% of a 1" format, a 1/2" format is 75% of a 2/3" format and a 1/3" format is 75% of a 1/2" format.

Camera to Monitor Magnification

Camera Format	Monitor Size (diagonal)					
	9"	14"	15"	18"	20"	27"
1/3"	38.1X	59.2X	63.5X	76.2X	84.6X	114.1X
1/2"	28.6X	44.5X	47.6X	57.2X	63.5X	85.7X
2/3"	20.8X	32.3X	34.6X	41.6X	46.2X	62.3X
1"	14.3X	22.2X	23.8X	28.6X	31.8X	42.9X
4/3"	10.6X	16.4X	17.6X	21.1X	23.5X	31.7X

C-Mount and CS-Mount Lens Compatibility

When using a C-mount lens for a CS-mount camera, a C/CS-mount adapter (5mm thick) is required.

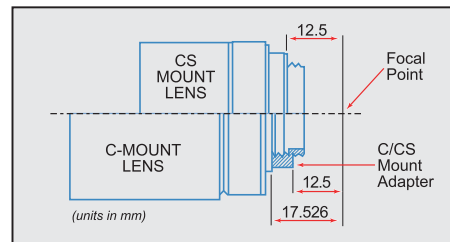

General Lens Formulas

Magnification

$m = \text{Image Size} / \text{Object Size}$

Effective F/#

$\text{Eff. F/\#} = F/\# (m+1)$

Object to Image Distance

$OI = [FL \times (1+m)^2] / m$

$OI = m(FL) + (FL + VOA + BF) + FL / m$

VOA = Vertex to Vertex Lens Length

Clear Aperture (Minimum)

$\text{Aperture} = FL / (F/\#)$

Depth of Focus

$\text{DoF} = 0.00002 / NA^2$ (in inches)

$\text{DoF} = 0.0005 / NA^2$ (in mm)

Object to Lens Distance

$OL = FL + FL(m)$

Conversion Factors

1 inch = 25.4 millimeters

1 meter = 39.37 inches

1 degree = $\pi / 180$ radians

1 degree = 0.0174533 radians

1 micron (μ) = 0.001 millimeter

1 micron (μ) = 1,000 nanometers

1 micron (μ) = 10,000 angstroms

Lens to Image Distance

$LI = FL + FL(m)$

(~ distance to the nodal points:

$FL + FL(m)$ to the front vertex.)

$F/\# = 1 / (2NA)$

$F/\# = FL / \text{Entrance Pupil Diameter}$

$NA = 1/2 F/\#$

$NA = \sin \theta/2$

Online Resources

The Optical Wizard

With our patented online tool, the Optical Wizard, you can easily configure complete imaging solutions. The Wizard offers customized suggestions to suit your needs and budget.

www.opticalwizard.com



Digital Resources Library

Navitar offers a number of digital resources for your reference, including brochures and interactive catalogs.

www.navitar.com/support/resources/

How to Order



Call 585-359-4000 or call us toll-free at 800-828-6778.



Visit www.navitar.com for secure and simple online ordering, or email us at info@navitar.com.



Submit your purchase order by fax at 585-359-4999.

Navitar Company Locations

Rochester, New York - Headquarters

Denville, New Jersey

San Ramon, California

Ottawa, Canada

Proudly Exporting to

50
COUNTRIES

Designing and
manufacturing quality
optical lens assemblies
in our Rochester NY
facility for over 45 years.





200 Commerce Drive
585.359.4000
info@navitar.com

Rochester, NY 14623
800.828.6778
www.navitar.com

01/2020